



MS 22"

ITV
ICE makers



DESPIECE / REPUESTOS
EXPLODED VIEW / SPARE PARTS
EXPLOSIONSZEICHNUNG / ERSATZTEILE
VUE ÉCLATÉE / PIÈCES DÉTACHÉES
ESPLOSO / RICAMBI

AIR CONDENSER UNIT



MS 22"

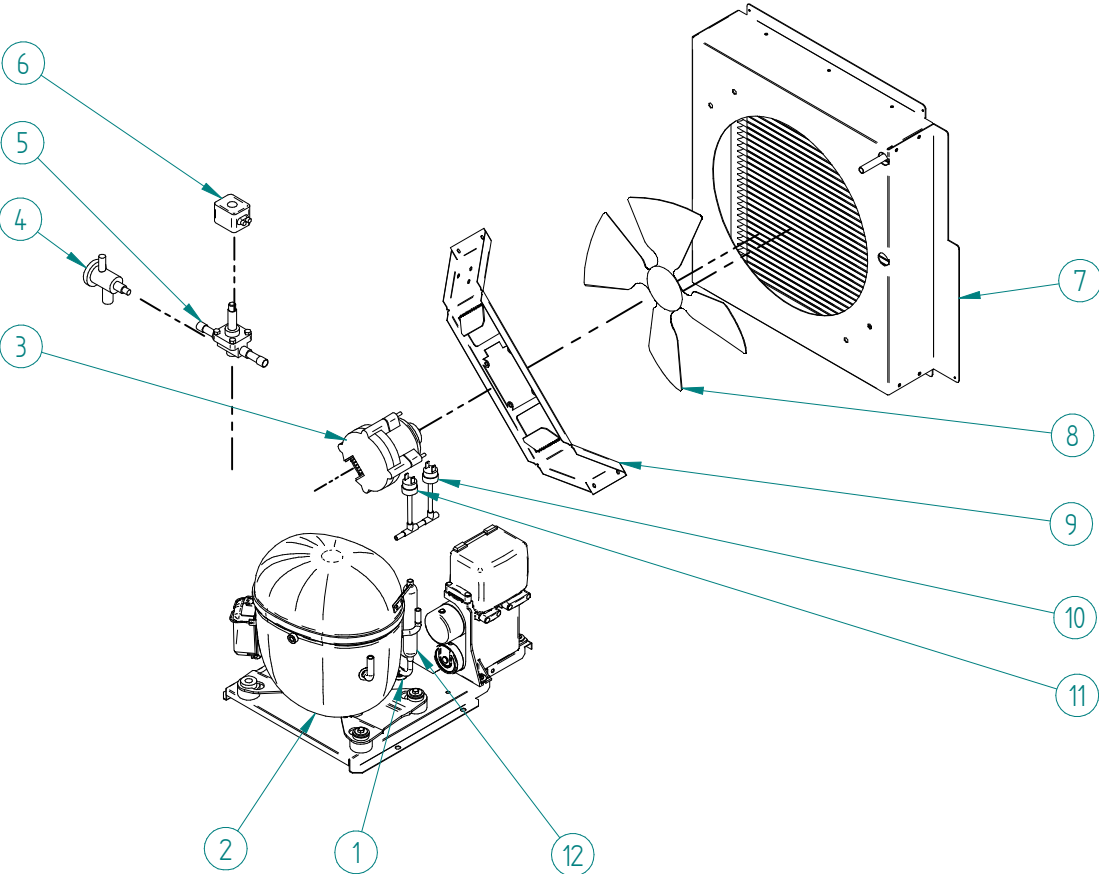

ITEM	DESCRIPTION	22"		
		MS 220	MS 300	
1	PLASTIC CLIP 1/4"	3533		
2	COMPRESSOR	220V/50HZ	31309	32764
		220V/60HZ	-	34965
		115V/60HZ	31457	-
3	FAN MOTOR	220V/50-60HZ	32654A	
		115V/60HZ	32655	-
3	FAN MOTOR WIRE	220V/50-60HZ	32656	
		115V/60HZ	32657	-
4	EXPANSION VALVE	31524		
5	HOT GAS VALVE - BODY	6396	31014	
6	HOT GAS VALVE - COIL	220V/50-60HZ	5173	30028
		115V/60HZ	5414	-
7	AIR CONDENSER	32836	34202	
8	FAN BLADE	6398		
9	FAN SUPPORT	6501	32653	
10	HIGH PRESSURE SWITCH	31660E		
11	FAN CONTROL PRESSURE SWITCH	31160E		
12	DRIER FILTER	7896		

WATER CONDENSER UNIT



MS 22"

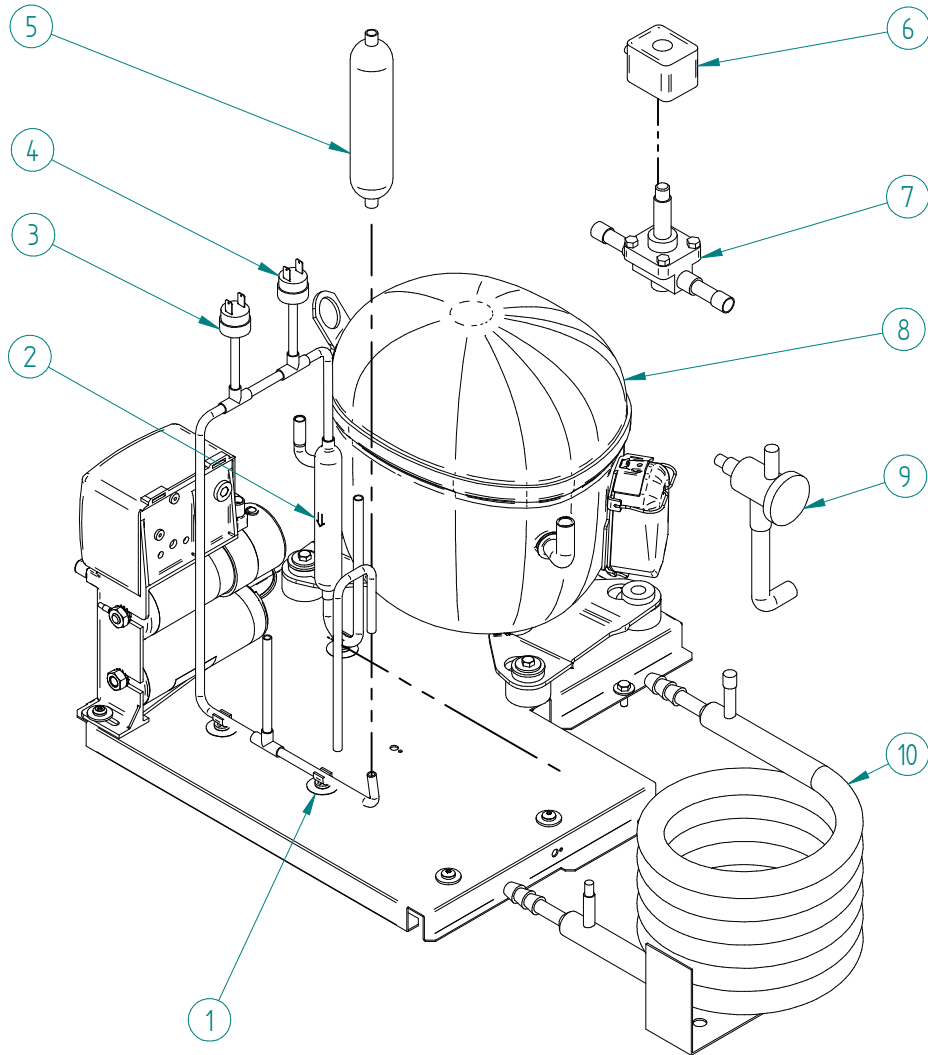

ITEM	DESCRIPCION	22"
		MS 300
1	CLIP 1/4"	3533
2	DRIER FILRTER	7896
3	FAN CONTROL PRESSURE SWITCH	31160E
4	HIGH PRESSURE SWITCH	31660E
5	SEP PARTICLES	1570
6	HOT GAS VALVE - COIL	30028
7	VALVULA GAS CALIENTE	31014
8	COMPRESOR	32764
9	EXPANSION VALVE	31524
10	CONDENSATOR	33671

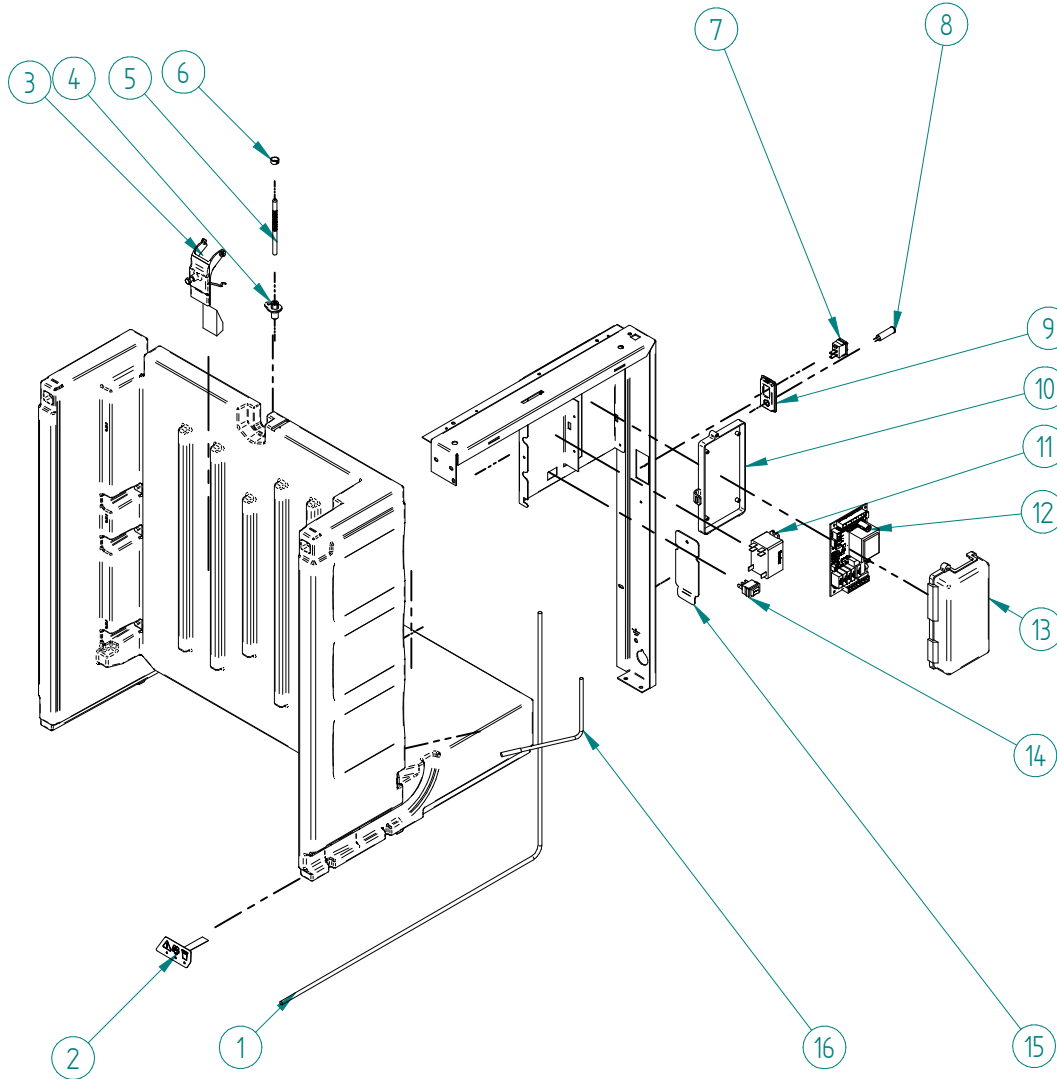

ITEM	DESCRIPTION	22"	
		MS 220	MS 300
1	DISPLAY WIRE	220V/50-60HZ	34577
		115V/60HZ	N/A -
2	DISPLAY	220V/50-60HZ	34558
		115V/60HZ	N/A -
3	THICKNESS ICE BLOCK SENSOR		30894B
4	SUPPORT WATER LEVEL SENSOR		8670
5	ISOLATED WATER LEVEL SENSOR		30982
6	COMPRESSION RING		504
7	MAIN SWITCH		32416
8	BLUE LED		32415
9	MAIN SWITCH SUPPORT		32441
10	ELECTRIC BOX		2181
11	RELAY FINDER	220V/50-60HZ	32502
		115V/60HZ	32501 -
12	ELECTRONIC BOARD	220V/50-60HZ	34642
		115V/60HZ	6253D -
13	ELECTRIC BOX COVER		30861
14	SWITCH (ICE-STANDBY-WASH)		6161
15	JUNCTION BOX COVER	220V/50-60HZ	N/A N/A
		115V/60HZ	32349 -
16	CURTAIN SENSOR		6521A

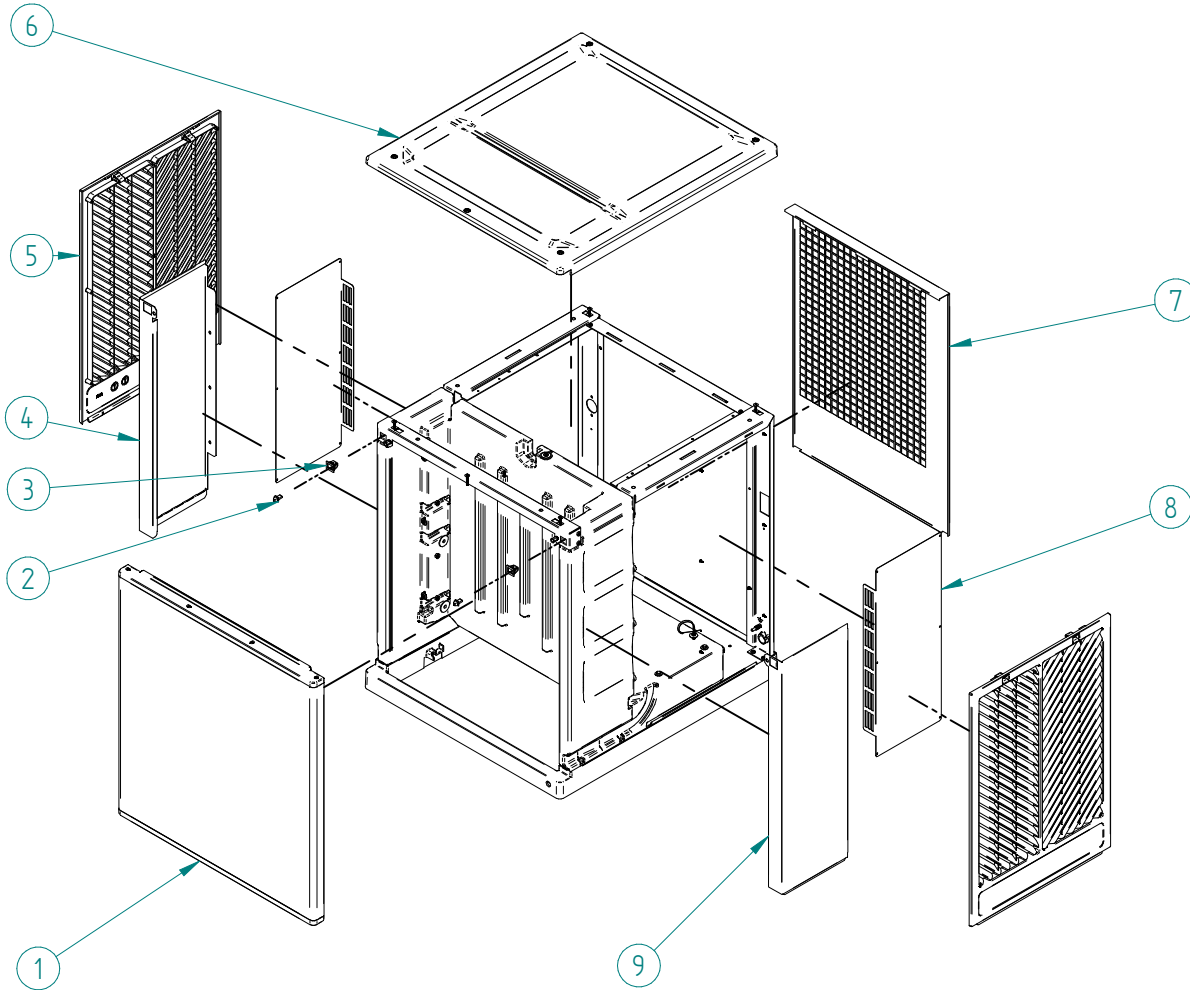

ITEM	DESCRIPTION	22"	
		MS 220	MS 300
1	FRONT PANEL	30749	6269
2	MALE PANEL CLIP	6181	
3	FEMALE PANEL CLIP	6180	
4	LEFT PANEL	30748	6328
5	SIDE LOUVER	30424	6084
6	TOP PANEL	30423	6073
7	REAR PANEL	30746	6315U
8	WIRE PROTECTION GRILL	30908	N/A
9	RIGHT PANEL	30747	6327

HYDRAULIC PARTS



MS 22"

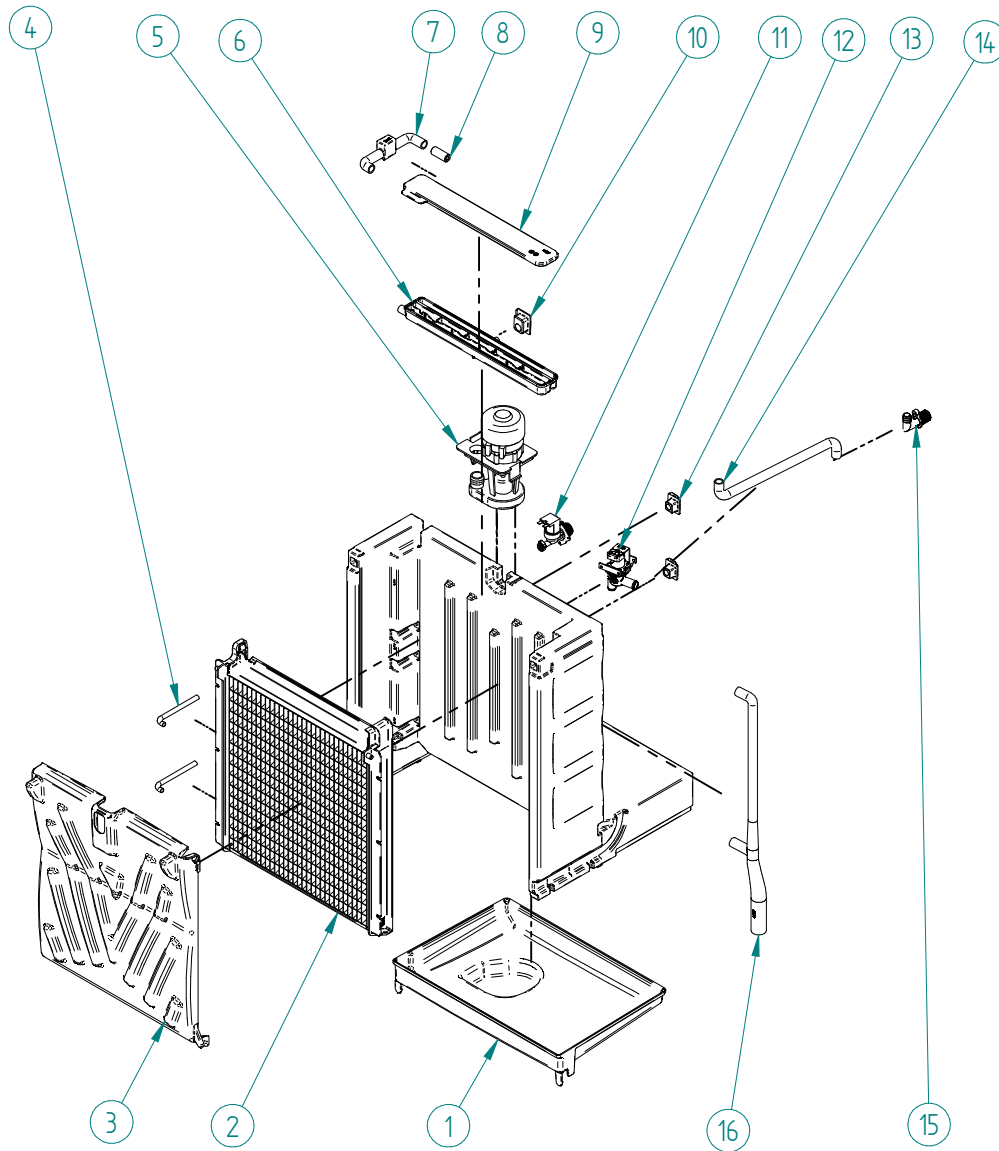

ITEM	DESCRIPTION	22"	
		MS 220	MS 300
1	WATER BIN	30413	
2	EVAPORATOR FULL DICE ASSY	31947A	30907
	EVAPORATOR HALF DICE ASSY	31933A	30752
3	CURTAIN	32252K	30420K
4	PIPE	30690	
5	WATER PUMP	220V/50-60HZ	6509
		115V/60HZ	6508 -
6	WATER DISTRIBUTOR	30422	
7	UPPER WATER PUMP DISCHARGE TUBE	30684	
8	WATER FLOW RESTRICTOR 7MM	30784	
	WATER FLOW RESTRICTOR 9MM	31246	
9	DISTRIBUTOR COVER	30427	
10	WATER DISTRIBUTOR PROTECTOR	30682	
11	INLET WATER VALVE	220V/50-60HZ	6980
		115V/60HZ	31810 -
12	WATER DRAIN VALVE	220V/50-60HZ	6183
		115V/60HZ	6182 -
13	PIPE PROTECTION	30683	
14	DRAIN TUBE	220V/50-60HZ	30468A
		115V/60HZ	31846 -
15	DRAIN FITTING	220V/50-60HZ	30850
		115V/60HZ	31723 -
16	LOWER WATER PUMP DISCHARGE TUBE	30469	