

pipe connection drawing (elevation)

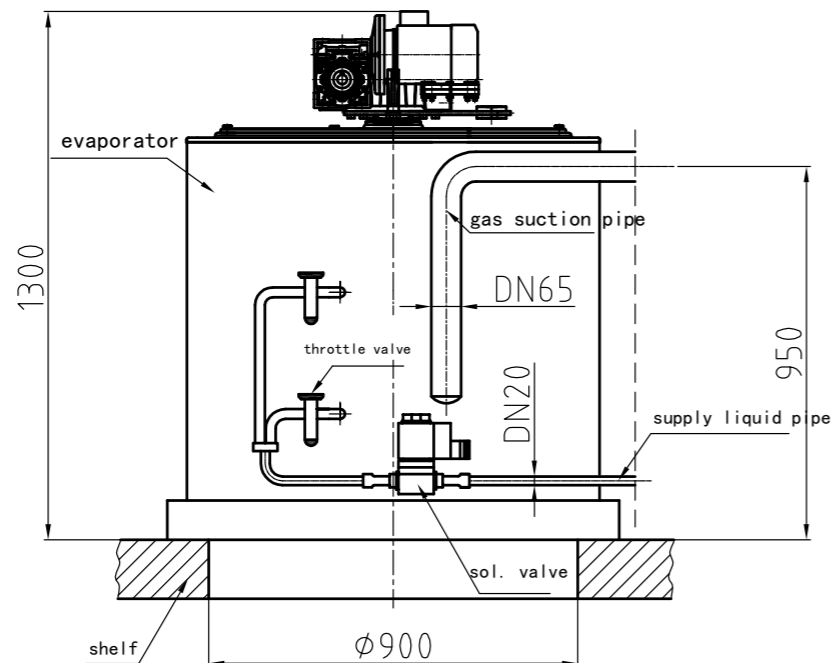

pipe connection drawing (planform)

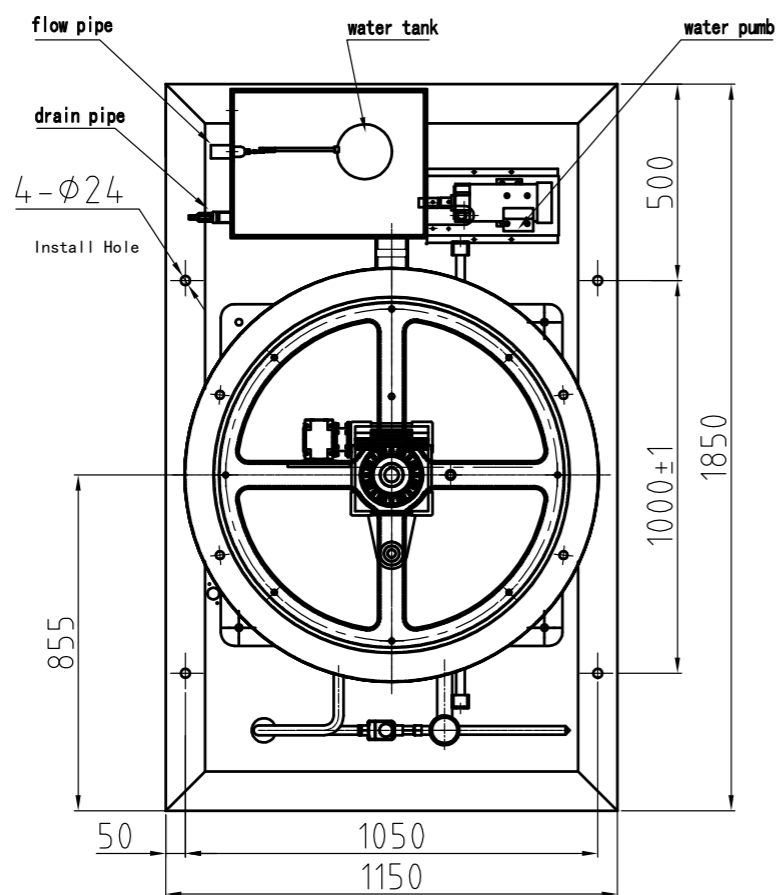

ice exit dimension

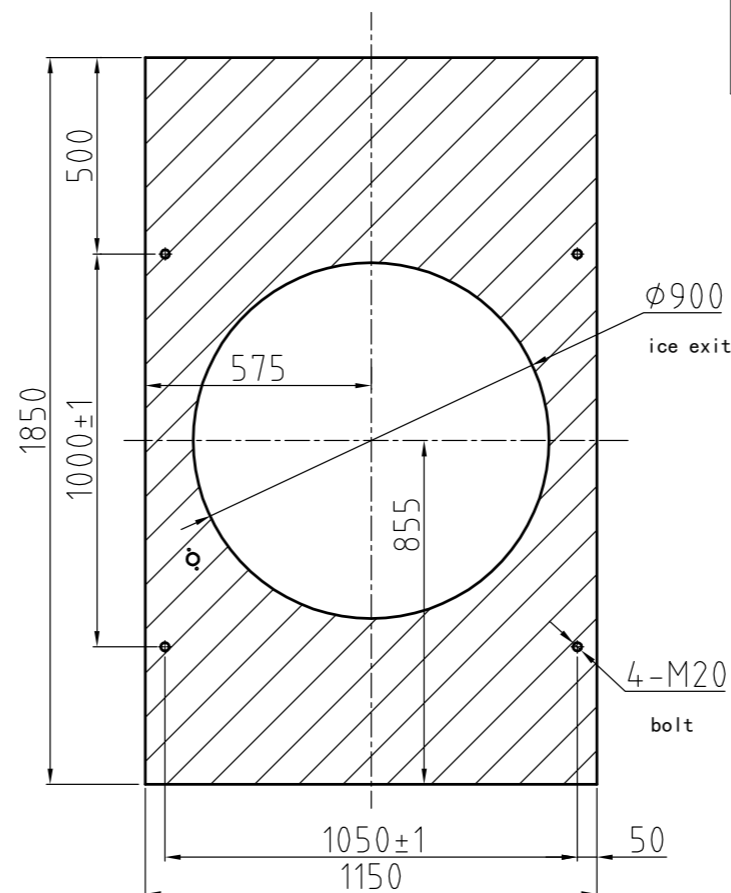

TECHNICAL DATA FOR FF5E ICE SYSTEM

Type	
Ice capacity/Day	5 t
refrigerant	R449
Ambient Temp.	25 °C
Enter water Temp.	16 °C
cooling capacity	28KW
evaporating temp.	-22°C
Power	380V/50Hz/3N
Speed reducer power	180 W
Water pump power	65 W
Water demand	208 L/h
turbidity	≤20 mg/kg
Flowpipe Interface	3/4" GAS
Drainpipe external Dia.	φ21
Outline Dimension (mm)	1850 X 1150 X 1300
Net Weight	350 kg

Technical data are subject to change without prior notice.

Propiedad Reservada. ITV se reserva la propiedad del presente documento, por lo tanto no podrá ser reproducido o comunicado a terceros sin la debida autorización de ITV. Intellectual Property. ITV reserves the property of this document. Any reproduction or communication to other parties is not permitted without ITV authorization.

Rev.	Fecha Date	Descripción Description						Dibujado Drawn by			
-	-	Código Code	Material	Espesor Thickness	Aprobado por Approved by	Fecha Date	Hoja Sheet	Tamaño Size	Escala Scale		
					I.SEGUI	15/06/2021	1/1	A3		Tolerancias no indicadas según ISO 2768-1 grado medio Follow ISO 2768-1 medium class for not defined tolerances Medidas mm Measurement mm	
		Nº De Plano Drawing No. Item / Revision	Denominación Description SCALA 5TN								