

SCALA 1000 ON BOARD SW COMPACT

MODULAR FLAKE ICE MACHINE

THREE PHASE
400 V / 50 Hz

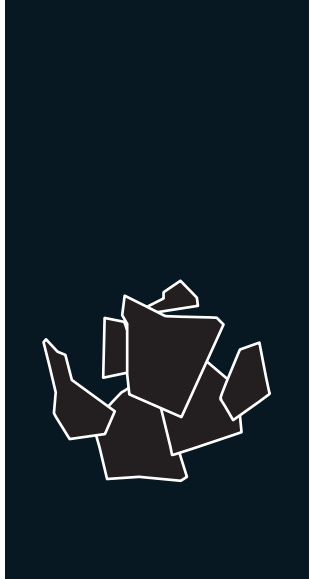

FEATURES CARACTERÍSTICAS

- ▶ **PRODUCES COLD AND DRY FLAT FLAKES 1,6 TO 2 MM THICK WITH SALT WATER.**
PRODUCE ESCAMAS PLANAS MUY FRÍAS Y SECAS DE 1,6 A 2 MM DE ESPESOR CON AGUA SALADA.
- ▶ **HIGH EFFICIENCY STAINLESS STEEL EVAPORATOR RESISTANT TO THE AGGRESSIVE MARINE ENVIRONMENT.**
EVAPORADOR EN ACERO INOXIDABLE RESISTENTE A AMBIENTES MARINOS AGRESIVOS.
- ▶ **BASED ON A STATIC CYLINDER WHICH IS FREE FROM SWIVEL JOINTS COUPLED WITH A HELICAL MILLING TOOL THAT DETTACHES THE ICE WITHOUT ANY STRAINED OR FORCED MOVEMENTS.**
FUNCIONAMIENTO BASADO EN UN CILINDRO ESTÁTICO SIN JUNTAS GIRATORIAS Y CON UNA FRESA HELICOIDAL QUE DESPEGA EL HIELO SIN TENSIONES NI ESFUERZOS.
- ▶ **THERMOSTATIC EXPANSION VALVE / LIQUID SOLENOID VALVE / ELECTRONIC STOP SYSTEM / DRIVE DIRECT GEAR MOTOR / MAGNETIC DRIVE PUMP.**
VÁLVULA DE EXPANSIÓN TERMOSTÁTICA / VÁLVULA SOLENOIDE DE LÍQUIDO / PARO POR LLENADO DE CUBA CON CÉLULA FOTOELÉCTRICA / SISTEMA DE PARADA ELECTRÓNICO / MOTORREDUCTOR DE ATAQUE DIRECTO / BOMBA DE ARRASTRE MAGNÉTICO.
- ▶ **ELECTRONIC STOP SYSTEM / ELECTRICAL CONTROL PANEL / DRIVE DIRECT GEAR MOTOR / MAGNETIC DRIVE PUMP / LOW WATER SAFETY DEVICE.**
SISTEMA DE PARO ELECTRÓNICO / CUADRO ELÉCTRICO DE REGULACIÓN / MOTORREDUCTOR DE ATAQUE DIRECTO / BOMBA DE ARRASTRE MAGNÉTICO / SEGURIDAD ANTE FALTA DE AGUA.
- ▶ **STAINLESS STEEL SUPPORT STRUCTURE.**
ESTRUCTURA DE SOPORTE EN ACERO INOXIDABLE.
- ▶ **CONTROLLERS TO DETECT: LOW WATER LEVEL (FLOAT VALVE), TEMPERATURE RISE DUE TO MOTOR OVERLOAD (THERMAL OVERLOAD RELAY) OR FULL BIN (PHOTOELECTRICAL SENSOR).**
CONTROLES PARA DETECTAR: BAJO NIVEL DE AGUA, AUMENTO DE TEMPERATURA POR SOBRESFUERZO EN EL MOTORREDUCTOR Y ALMACÉN LLENO.
- ▶ **ELECTRIC MANOEUVRE PROTECTED BY A POLYESTER WATERPROOF ELECTRICAL BOX.**
MANIOBRA ELÉCTRICA PROTEGIDA POR UN CUADRO ELÉCTRICO EN POLIÉSTER RESISTENTE AL AGUA.



	24 H	10°C (Kg)	15°C (Kg)	(mm)	(mm)	
SCALA 1000 ON BOARD SW COMPACT		1.100	1.000	Width 1.405 Depth 1.645 Height 1.447	Width 1.575 Depth 1.785 Height 1.890	FLAKE ICE -7°C Ice Temperature

ACCESSORIES ACCESORIOS

INCLUDED



WATER INLET FILTER GASKET
JUNTA DE FILTRO DE ENTRADA DE AGUA



WATER INLET HOSE
MANGUERA DE ENTRADA DE AGUA



WATER OUTLET HOSE
MANGUERA DE DESAGÜE

OPTIONAL (NOT INCLUDED)



ICE DROP CHUTE
TUBO DE CAÍDA DE HIELO



SALT DOSING PUMP WITH TANK
BOMBA DOSIFICADORA DE SAL CON DEPÓSITO



REMOTE SWITCH
INTERRUPTOR REMOTO



REMOTE SWITCH & WEEKLY PROGRAMMER
INTERRUPTOR REMOTO CON PROGRAMADOR SEMANAL



EXTERNAL STOP FULL BIN PHOTO CELL
SENSOR DE PARO EXTERNO POR LLENADO

SCALA 1000 ON BOARD SW COMPACT

RIGHT SIDE VIEW
VISTA LATERAL DERECHA

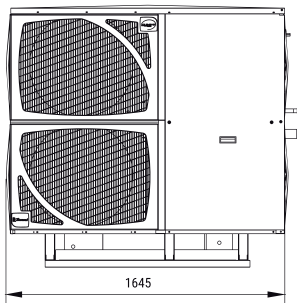

FRONTAL VIEW
VISTA FRONTAL

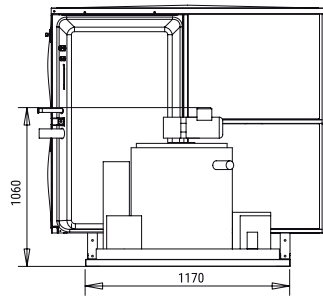

LEFT SIDE VIEW
VISTA LATERAL IZQUIERDA

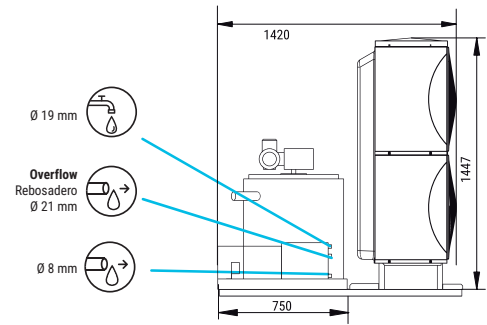

CENTRAL CROSS SECTION VIEW OF THE BASE
VISTA DE LA BASE DESDE SECCIÓN CENTRAL

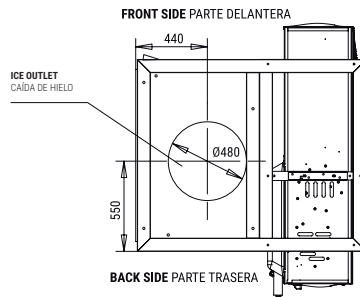

REAR VIEW
VISTA TRASERA

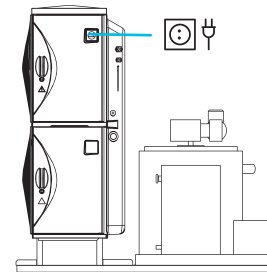

* All measurements in mm.
* Todas las cotas en mm.

OPERATING CONDITIONS CONDICIONES DE TRABAJO

PRODUCTION 50Hz PRODUCCIÓN 50 Hz

±10% V

10°C/43°C

5°C/38°C

1 bar/6 bar

V	Hz	ph
400	50	3N

SCALA 1000 ON BOARD SW COMPACT

°C	10°	15°	21°	30°
°F	50°	60°	70°	86°
10°	1100	1400	900	830
50°				
21°	1090	1000	875	790
68°				
32°	1020	950	800	730
90°				
43°	860	780	650	600
109°				

SCALA 1000 ON BOARD SW COMPACT

°C	10°	15°	21°	30°
°F	50°	60°	70°	86°
10°	1023	1302	837	772
50°				
21°	1014	930	814	735
68°				
32°	949	884	744	679
90°				
43°	800	725	605	558
109°				

MODELS
MODELOS

Temp.EV. (°C)	ASHRAE CONDITIONS (W) (BTu/h)	(W) 43°C	(n.) (mm²)	FUSE	100 Kg (Kw/h)	(l/h)	HEAT REJECTED (W) (BTu/h)	(Kg)	(Kg)	(m³)
-32	5.500 18.767	3.100	5 2.5	16	10,3	41.6	6.600 22.520	490	550	5,31

SCALA 1000 ON BOARD SW COMPACT



ITV ICE MAKERS, S.L.
POL. IND. SECTOR 13, AVDA. DELS HOSTALERS, 2
46394 RIBARROJA DE TURIA, VALENCIA, SPAIN
PHONE: +34 96 166 75 75 | FAX: +34 96 166 81 00
info@itv.es | www.itv.es

SERVICE
SERVICIO ASISTENCIA TÉCNICA
service@itv.es
Skype: ITV.Service
+34 961 667 639
8:00AM | 7:00PM

Subject to certain limitations
and exclusions. Only spare parts.
Sujeto a limitaciones y exclusiones.
Solo piezas de repuesto.

