

**ITV**  
ICE makers

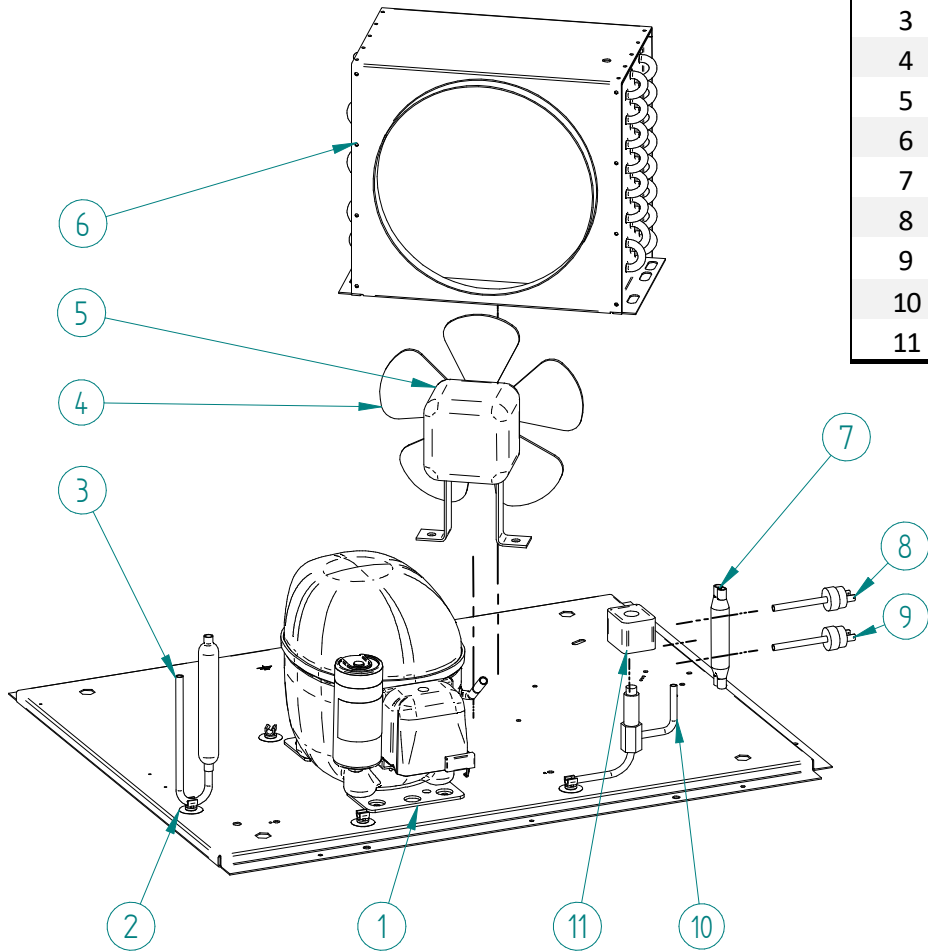

DESPIECE / REPUESTOS  
EXPLODED VIEW / SPARE PARTS  
EXPLOSIONSZEICHNUNG / ERSATZTEILE  
VUE ÉCLATÉÉ / PIÈCES DÉTACHÉES  
ESPLOSO / RICAMBI



ITEM	DESCRIPTION	35	45	60	80	135
1	COMPRESSOR*	30GR - 220V/50HZ	33302	33303	31306	31309
	40GR - 220V/50HZ	33301	33305		31307	
	220V/60HZ		33302	32761	33813	
2	CLIP TUBE			3533		
3	FILTER DRIER			7896		
4	FAN BLADE		4887			4231
5	FAN MOTOR	220V/50-60HZ		28		445
6	AIR CONDENSER		486A	487A	32251	32730
7	PRESSURE SWITCH COLLECTOR			31444		
8	FAN CONTROL PRESSURE SWITCH			31160E		
9	HIGH PRESSURE SWITCH			31660E		
10	HOT GAS VALVE - BODY			1473		6396
11	HOT GAS VALVE - COIL	220V/50-60HZ		5173		

\*SERIAL NUMBER MUST BE PROVIDED

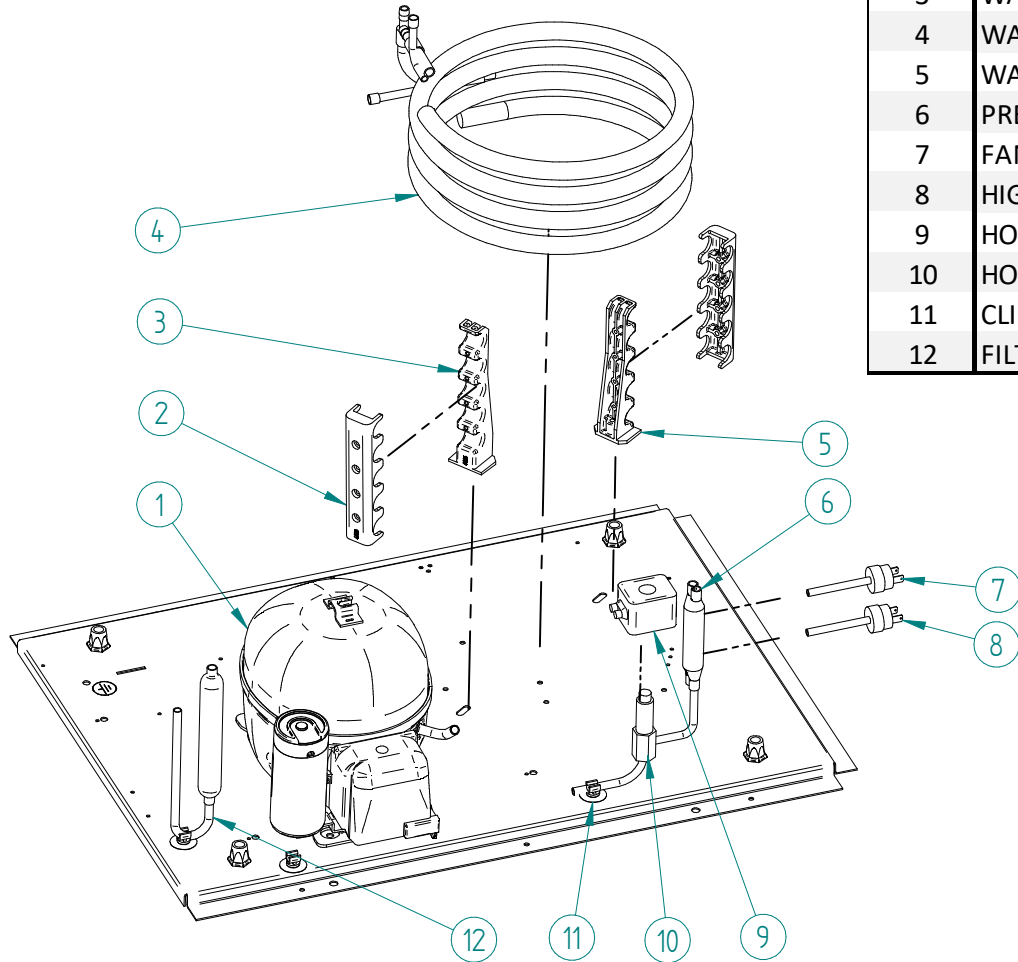

ITEM	DESCRIPTION	35	45	60	80	135
1	COMPRESSOR* 30GR - 220V/50HZ	33302	33303		31306	31309
	40GR - 220V/50HZ	33301			33305	31307
	220V/60HZ		33302		32761	33813
2	WATER CONDENSER EXTERNAL SUPPORT			4038		
3	WATER CONDENSER UPPER SUPPORT			4036		
4	WATER CONDENSER	5242	33035	5244	5246	
5	WATER CONDENSER LOWER SUPPORT			4037		
6	PRESSURE SWITCH COLLECTOR			31444		
7	FAN CONTROL PRESSURE SWITCH			31160E		
8	HIGH PRESSURE SWITCH			31660E		
9	HOT GAS VALVE - COIL 220V/50-60HZ			5173		
10	HOT GAS VALVE - BODY		1473			6396
11	CLIP TUBE			3533		
12	FILTER DRIER			7896		

\*SERIAL NUMBER MUST BE PROVIDED

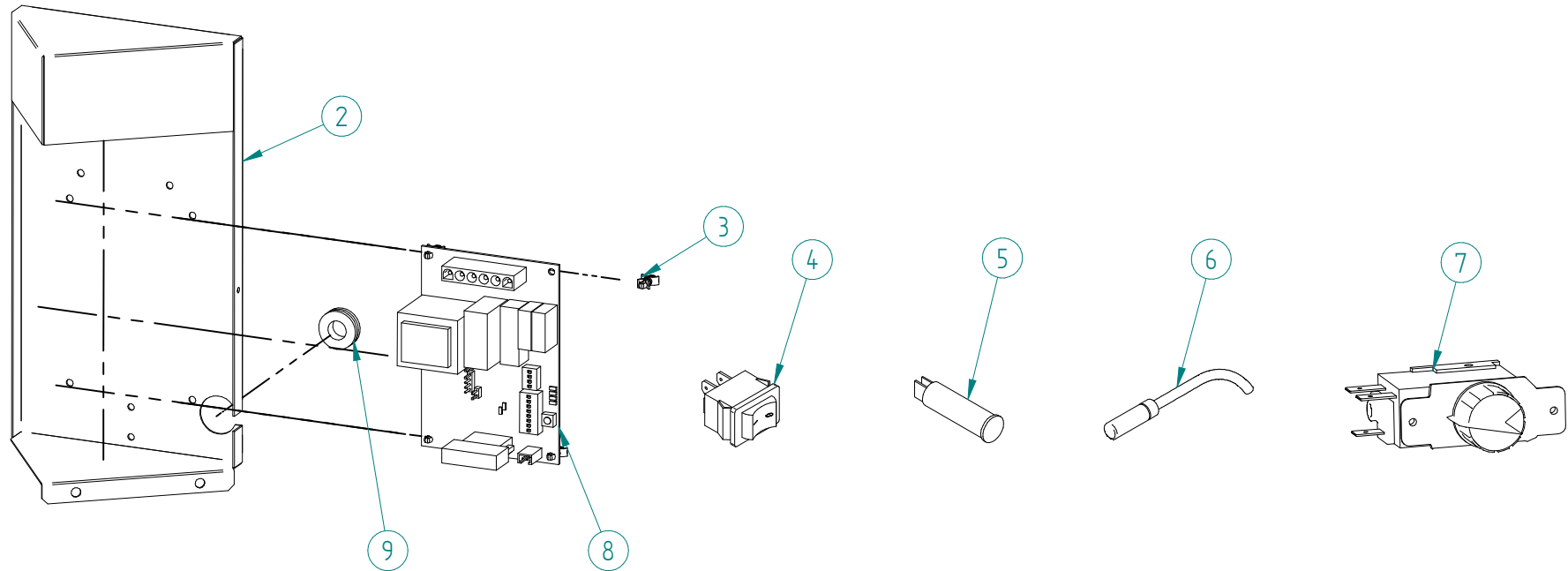
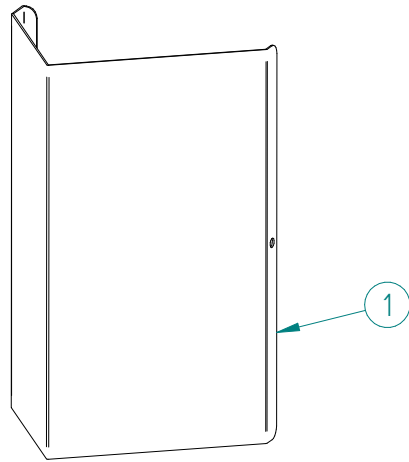

ITEM	DESCRIPTION	35	45	60	80	135
1	ELECTRIC BOX COVER			31571A		
2	ELECTRIC BOX SUPPORT			31823A		
3	ELECTRONIC BOARD CLIP			31544		
4	MAIN SWITCH*			32416		
5	LED*			32415		
6	TEMPERATURE PROBE			32644		
7	BIN THERMOSTAT			31758		
8	ELECTRONIC BOARD 220V/50-60HZ			33614		
9	WIRE HOLE			31746		

\*SERIAL NUMBER MUST BE PROVIDED

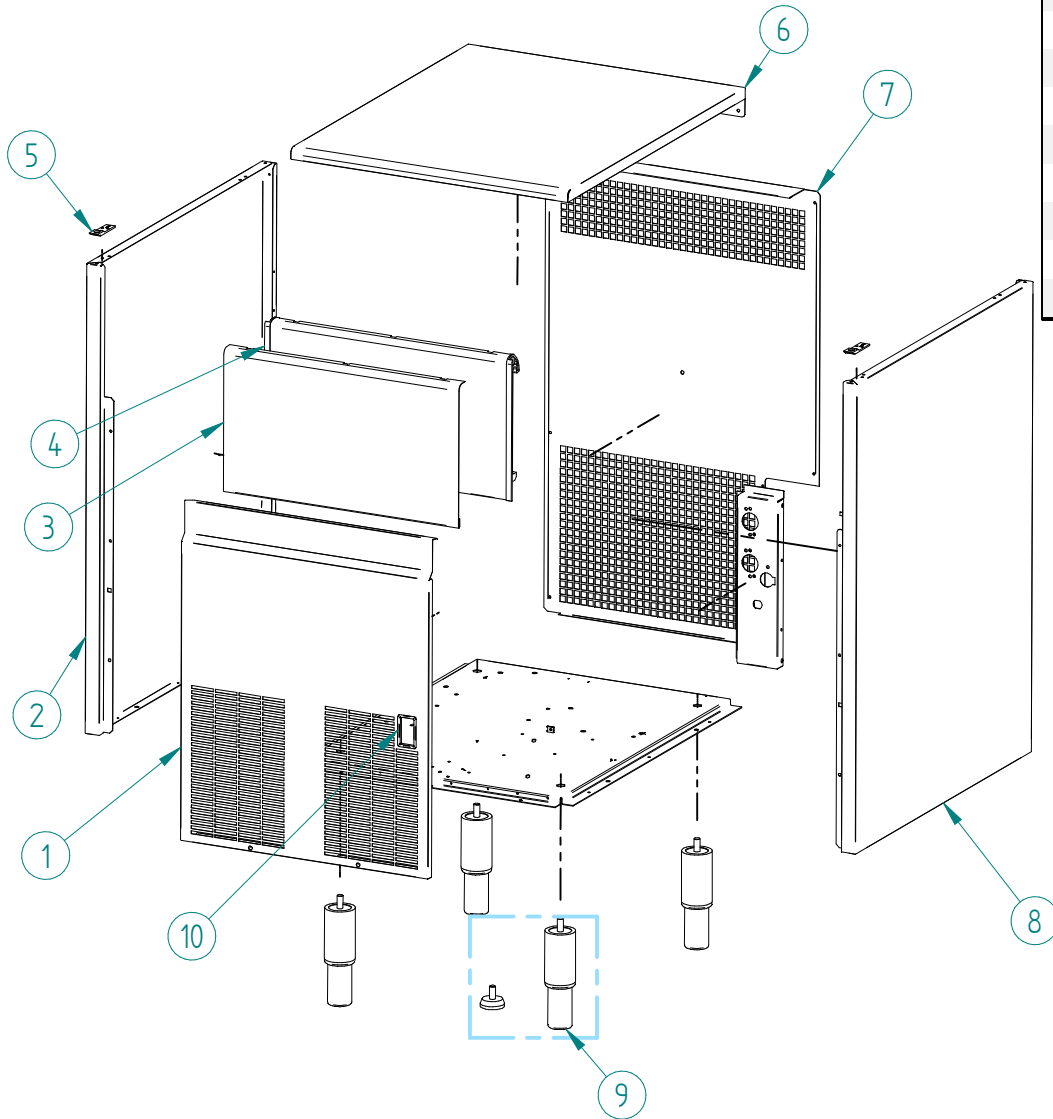

ITEM	DESCRIPTION	35/45	60	80	135
1	FRONT PANEL*	2086UA	2088UA	2089U	6453AU
2	LEFT PANEL	4811	4813	4815	4817A
3	DOOR COVER	4830	4831	4832	N/A
4	DOOR	4268A	4269A	4270A	31146
5	TOP PANEL FASTENING		8996		N/A
6	TOP PANEL	4818V1	4819V1	4820V1	4821V1
7	REAR COVER	4108U	4124U	4138U	4460U
8	RIGHT PANEL	4810	4812	4814	4816A
9	LEGS	4144			1478
10	MAIN SWITCH SUPPORT		32442		

\*SERIAL NUMBER MUST BE PROVIDED

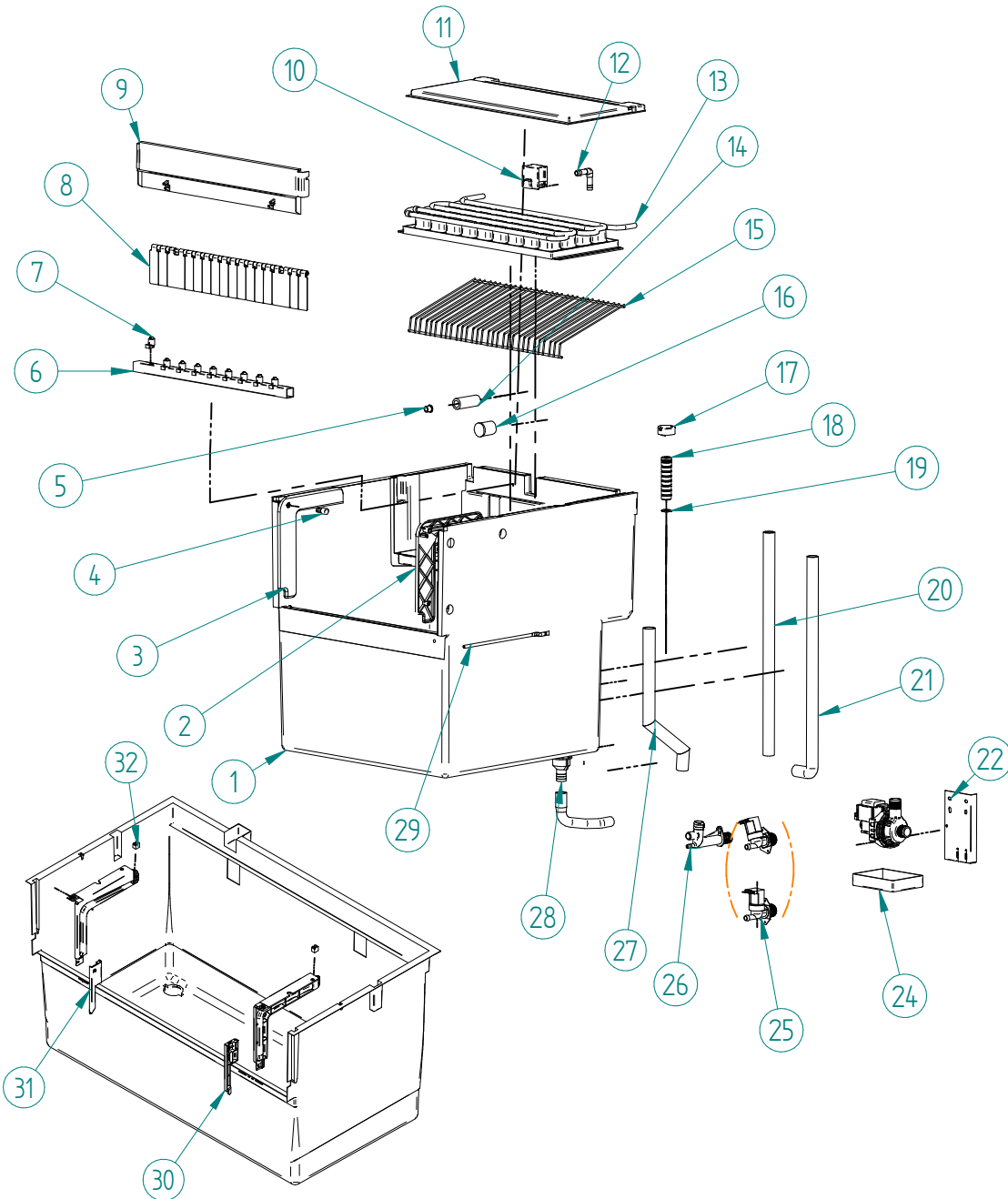

ITEM	DESCRIPTION	35/45	60	80	135	
1	BIN*	7460B	7461B	7462B	31012F	
2	RIGHT DOOR GUIDE		4272		30668A	
3	LEFT DOOR GUIDE		4273		30667A	
4	DOOR PIVOT		4276		N/A	
5	WATER FLOW RESTRICTOR	805		N/A		
6	SPRAY BAR	7454	7455	7456	7497	
7	SPRAY NOZZLE			526		
8	CURTAIN ASSEMBLY	8362	8363	8364A	5957	
9	CURTAIN HOLDER	8176	8177	8178	4464B	
10	WATER INLET*			32175		
11	EVAPORATOR COVER*	4433A	2297A	33709	33688	
12	WATER INLET PIPE*			32174		
13	EVAPORATOR*	30GR 40GR	7423B 31359B	7400A 31387A	7156A 31366A	7501A 31381
14	SPRAY BAR TUBE			4098		
15	ICE CUBES RAMP	8904C	8905A	8906A	8907B	
16	FILTER			4505		
17	OVERFLOW CAP			4427		
18	OVERFLOW PIPE			4426		
19	O-RING			4496		
20	WATER PUMP DISCHARGE TUBE	4713	4724	4727	4886	
21	WATER PUMP SUCTION TUBE	8829	8830		8831	
22	WATER PUMP SUPPORT	220V/50HZ 220V/60HZ		4613 32023		
23	WATER PUMP	220V/50HZ 220V/60HZ	4769		8687 31981	
24	WATER PUMP TRAY			4521		
25	INLET WATER VALVE 1B	220V/50-60HZ	6980 + 33033		6981+4527(X2)	
	INLET WATER VALVE 2B	220V/50-60HZ	(A)+(6980+4526)		(A)+(6980+33033)	
26	DRAIN FITTING		363		6206	
27	HARVEST DRAIN TUBE	4714	4726		4729	
28	BIN DRAIN TUBE		6021		1907	
29	THERMOSTAT TUBE	4624	4627		4624	
30	LOWER RIGHT DOOR GUIDE		N/A		30670	
31	LOWER LEFT DOOR GUIDE		N/A		30669	
32	DOOR STOPPER		N/A		1715	

\*SERIAL NUMBER MUST BE PROVIDED