



TECHNICAL MANUAL

HNG MODEL

INDICE

1. <i>INTRODUCTION</i>	3
1.1.- Warning.....	3
1.2.- Characteristics	5
1.3.- Reception of the machine.....	5
2. <i>WORKING</i>	6
3. <i>SPECS</i>	8
3.1.- Main dimensions	8
3.2.- Technical data.....	9
4. <i>INSTALLATION</i>	9
4.1.- Placing of the ice machine.....	9
4.2.- Dimensions of the accomodation	10
4.3.- Machine anchoring	12
4.4.- Water and drain.....	13
4.4.1 Water supply connection.....	14
4.2.4 Drain connection	14
4.5- Electric connection	15
5. <i>START UP</i>	15
6. <i>MAINTENANCE AND CLEANING PROCEDURES</i>	17
6.1.- Condenser / water filter	19
6.2.- Evaporator / water bin	19
6.3.- Ice bin	20
6.4.- External cleaning of the machine.....	20
6.5.- Water distributor and injectors	20
6.6.- Filters	21
6.7.- Water leakage checking	21
7. <i>CONTROL BOARD</i>	21
7.1.- User menú	22
7.2.- Installer menu.....	22
7.3.- Information menú	24
8. <i>DISPLAY'S ALARMS</i>	26
9. <i>USER TROUBLESHOOTING GUIDE</i>	27

1. INTRODUCTION

1.1.- Warnings

- This appliance is intended to be used in household and similar applications such as: staff kitchen areas in shops, offices and other working environments; farm houses and by clients in hotels, motels and other residential type environments; bed and breakfast type environment; catering and similar non-retail applications.
- The installation of this equipment should be done by the Technical Assistance Service department.
- The socket should always be placed on an accessible location.
- When positioning the appliance, ensure that the power cable is not trapped or damaged.
- If the supply cord is damaged, it must be replaced by the manufacturer, its service agent or similarly qualified persons in order to avoid hazard.
- Do not place multiple portable socket outlets or portable power sources in the rear of the appliance
- ALWAYS disconnect the power supply from the machine BEFORE any cleaning or maintenance service.
- Any change needed on the electrical installation for the appropriate connection of the machine, should be exclusively performed by qualified and certified professional personnel only.
- Any use by the ice maker not intended to produce ice, using drinking water, is considered inappropriate.
- It is extremely dangerous to modify or intend to modify this machine and shall make any type warranty void.
- This device is not intended for use by persons (including children) whose physical, sensory or mental capacities are limited, or who lack sufficient experience or knowledge, unless they are acting under the supervision of or have received instruction regarding proper use of the device from a person responsible for their safety. Children should be supervised to ensure they do not play with the device.
- Children should be monitored to assure that they should not play near the equipment.
- This machine is not intended to be used outdoors nor exposed to the rain
- This machine must be grounded to prevent possible discharges on persons or damage to the equipment. The machine must be grounded according to local and/or national regulations and regulations in each case. The manufacturer will not be responsible for the damage caused by the lack of grounding of the installation.
- To guarantee the efficiency of this machine and its correct operation, it is essential to adhere to the manufacturer's instructions, especially as regards maintenance and cleaning operations, which must only be carried out by qualified personnel.
- This equipment must be installed with adequate return flow protection to comply with federal, state and local codes that are applicable.

The company reserves the right to make changes in specifications and design without prior notice.

ATTENTION: *The intervention of unskilled people, besides being dangerous, can cause serious damage. In case of a breakdown, contact your distributor.*

REMEMBER THAT MAINTENANCE AND CLEANING OPERATIONS ARE NOT INCLUDED IN THE WARRANTY AND THEREFORE, WILL BE INVOICED BY THE INSTALLER.



This signal indicates “Risk of fire / Flammable materials” because of the use of flammable refrigerant.

For compression-type appliances that use flammable refrigerants should additionally consider the substance of the warnings listed below:

- Keep ventilation openings, in the appliance enclosure or in the built-in structure, clear of obstruction.
- Do not use mechanical devices or other means to accelerate the defrosting process, other than those recommended by the manufacturer.
- Do not damage the refrigerant circuit.
- Do not use electrical appliances inside the food storage compartments of the appliance, unless they are of the type recommended by the manufacturer.
- Do not store explosive substances such as aerosol cans with a flammable propellant in this appliance.

In case of refrigerant leakage:

- Do not generate flames close to the appliance.
- Do not switch on/off or plug in/off the appliance.
- To ventilate immediately the area where appliance is located by opening doors and/or windows.
- To call to an authorized technical service.

Disposal of the ice maker: ITV encourages to follow the regulations of each country regarding eco-friendly disposal of electric and electronic devices such this one. User who is wanting to dispose of this equipment must contact the manufacturer and follow the method to appropriate differentiated collection for the subsequent treatments.

The A-weighted sound pressure level is below 70 dB (A).

During cleaning or maintenance and when parts are replaced, the appliance must be disconnected from its power source or provide a disconnection with a locking system.

1.2.- Characteristics

The most important characteristics are:

- 18/8 stainless steel body;
- Telescopic maintenance slides;
- Anti-blocking injectors;
- Pump without seals;
- R290 refrigerant;
- High Security Pressure Switch;
- TRANSPARENT CUBES with most of the mains water.

1.3.- Reception of the machine

Inspect the outside packing. In case of damages, make the corresponding claim to the carrier. To confirm the existence of damages, unpack the machine in the presence of the carrier and state any damage on the equipment on the reception document or freight document.

Always state the machine number and model. This number is printed on three locations:

Packing

On the outside, it contains a label with the serial number.







Exterior of the unit

On the back panel of the unit, there is a label with the same characteristics as the previous one.

Nameplate

On the back of the machine.

SIN MARCA - NEUTRO <small>ESB40632291</small>				S/N: 18482065	
CD: 21160U					
Volt.	Ph.	Hz.	A.		
220-240	~	50	3.9	10	
Ref.	g.	w.	clas.		
R290	135	480	T		
condensacion-condensation-kondensation AIRE-AIR-LUFT			Made in Spain/EU		
					
					

Check that in interior of the machine the installation kit is complete and comprises:

- Scoop, four legs and manual.
- Warranty and serial number.

CAUTION: All packing elements (plastic bags, carton boxes and wood pallets) should be kept outside the reach of children, as they are a source of potential Hazard.

2. WORKING

ONCE THE MACHINE TURN ON, IT START WITH AN HARVEST SEQUENCE AND WATER INLET.

In this moment, the compressor is working, the water valves and hot gas valves are open. The necessary amount of water is loaded for the manufacture of the next ice cycle and the excess goes to the drain through the overflow of the highest level. Once passed the programmed time, the hot valves and water inlet valve close. The pump turns on and the water circulates between the injectors to the cube cells, where it freezes. At the same time, the evaporation temperature decrease, until the ice in the cube cells is formed, once passed this time, start the harvest cycle (1.5-2 minutes). Now, the pump turns off and hot gas valve and water inlet valve open. Once ended the harvest cycle, the machine starts again and when storage bin is full, the machine shuts off until enough ice has been removed from the storage bin. In order not to have unfinished ice cubes, if when the stock thermostat detects that the bin is full, the cycle has already started, it will finish it.

3. SPECS

3.1.- Main dimensions

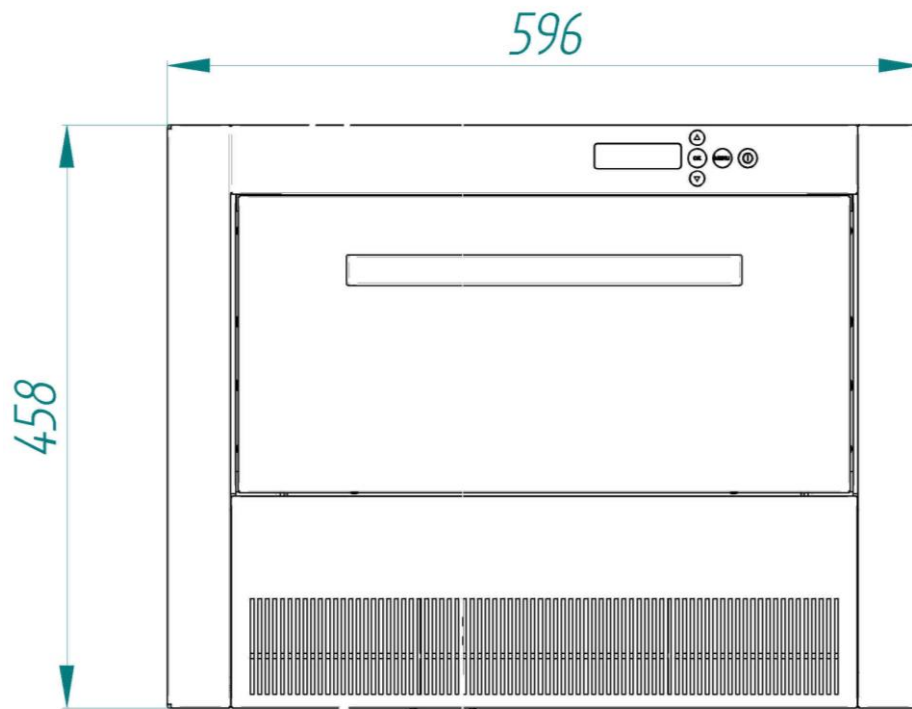

3.2.- Technical data

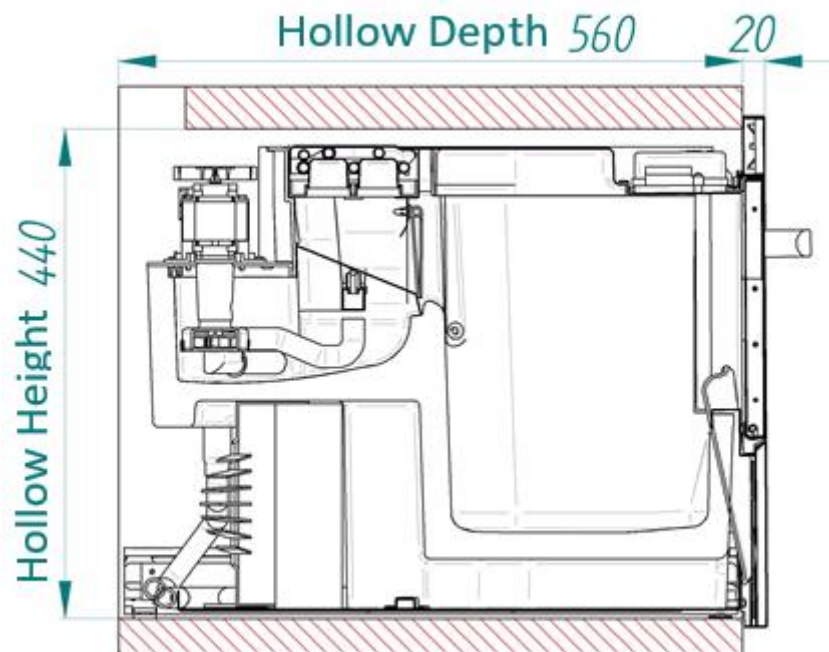

MODEL	WATER CONSUMPTION L/HORA (1)	NET WEIGHT (KG)	PACKAGING DIMENSIONS X*Y*Z	BRUTE WEIGHT (KG)	VOLUME (M ³)
HNG	2,65	40	670X685X570	46	0.27

MODEL	REFRIGERANT	REFRIGERANT LOAD (GR)	HIGH PRESSURE				LOW PRESSURE		TOTAL CURRENT (2) (A)	FUSE SAFETY (TO INSTALL) (A)	TOTAL POWER ABSORBED (2) (W)
			MIN		MAX		MEDIA				
			Kg/cm ²	psi	Kg/cm ²	psi	Kg/cm ²	psi			
HNG	R290	98	8	115	18	265	0.5	7	1,7	10	212

Production room 20°C – water 15°C	
Production Kg/ 24 h	13
Cycle time (minutes)	35
Ice cube	12
Weight for cube (gr)	27

- (1) Data obtained with Troom=20°C, Twater=15°C and water quality=500ppm
- (2) Maximum consumption obtained at Troom=43°C, according to UNE-EN standards for Class T climate classification (Tropicalized)

NOTE: Capillary-controlled expansion.

4. INSTALLATION

4.1.- Placing of the ice machine

The HNG ice Makers are designed to operate at room temperature between 5°C and 43°C and with water inlet temperature between 5°C and 35°C.

Below the minimum temperature there may be difficulties in the detachment of the ice cubes.

Above the maximum temperature, the life of the compressor is shortened, and the production is substantially lower.

The machines take in the air for the ventilation from the front and expel it from the rear. If the front air intake is not free or the outlet is completely or partially obstructed, the machine will not operate properly and production will be affected.

4.2.- Dimensions of the accommodation

For installing in the right way the ice maker, it is necessary that the location for the machine have the next dimensions: 560x440x560 mm, like below:

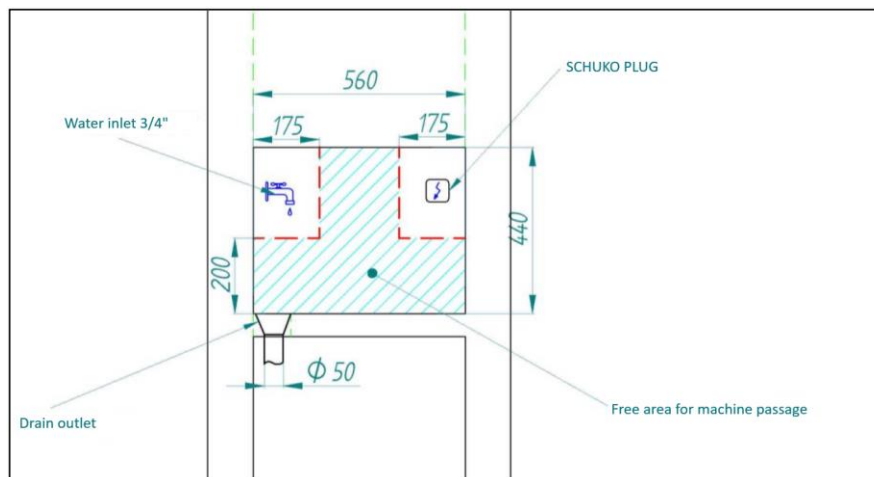
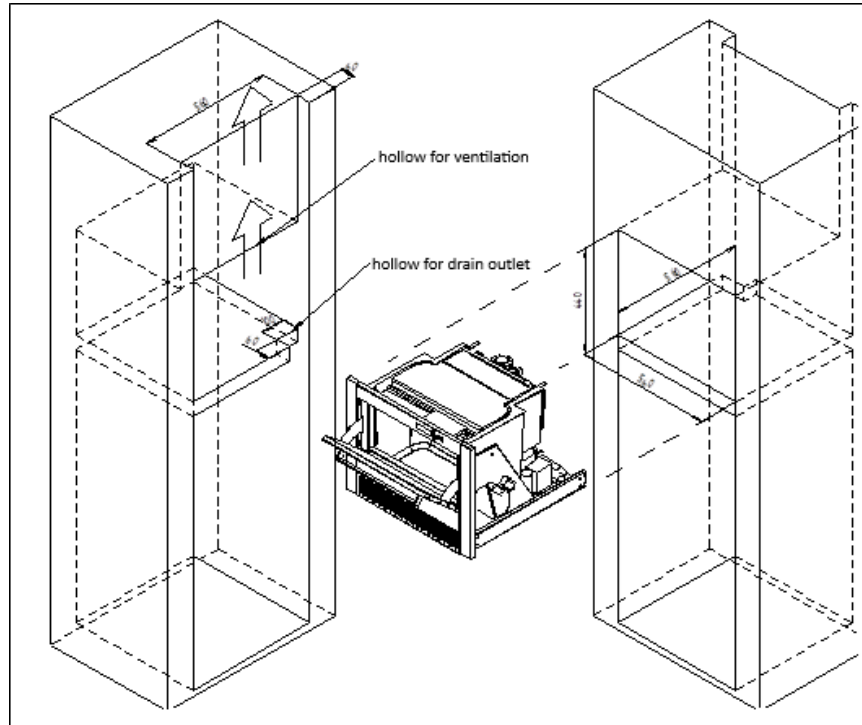

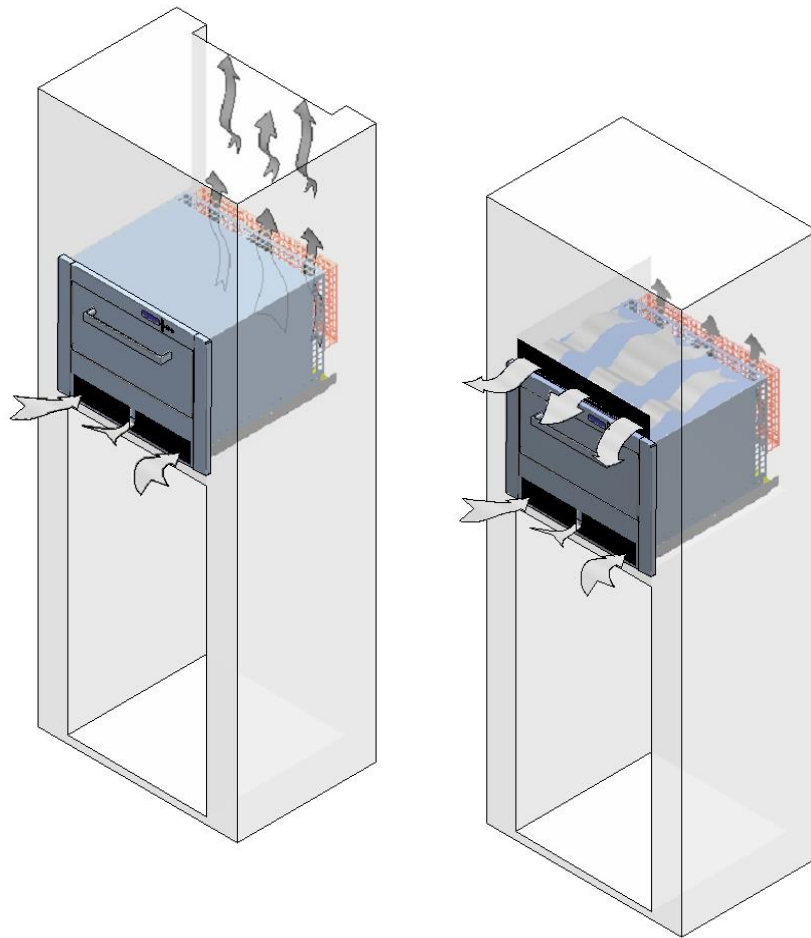

IMPORTANT

The locations must be allowing enough clearance for the air in the frontal grid. It can be a whole (with exterior exit) or a grid up to the machine.

And then, the location must be allowing enough clearance for water, drain and electrical connections.

It is very important that the water inlet piping do not pass near sources of heat so as not to lose ice production.

4.3.- Machine anchoring

Follow the next steps:

- 1- Screw the guides into the recess of the furniture so that they are horizontal and set back as indicated in the figure.

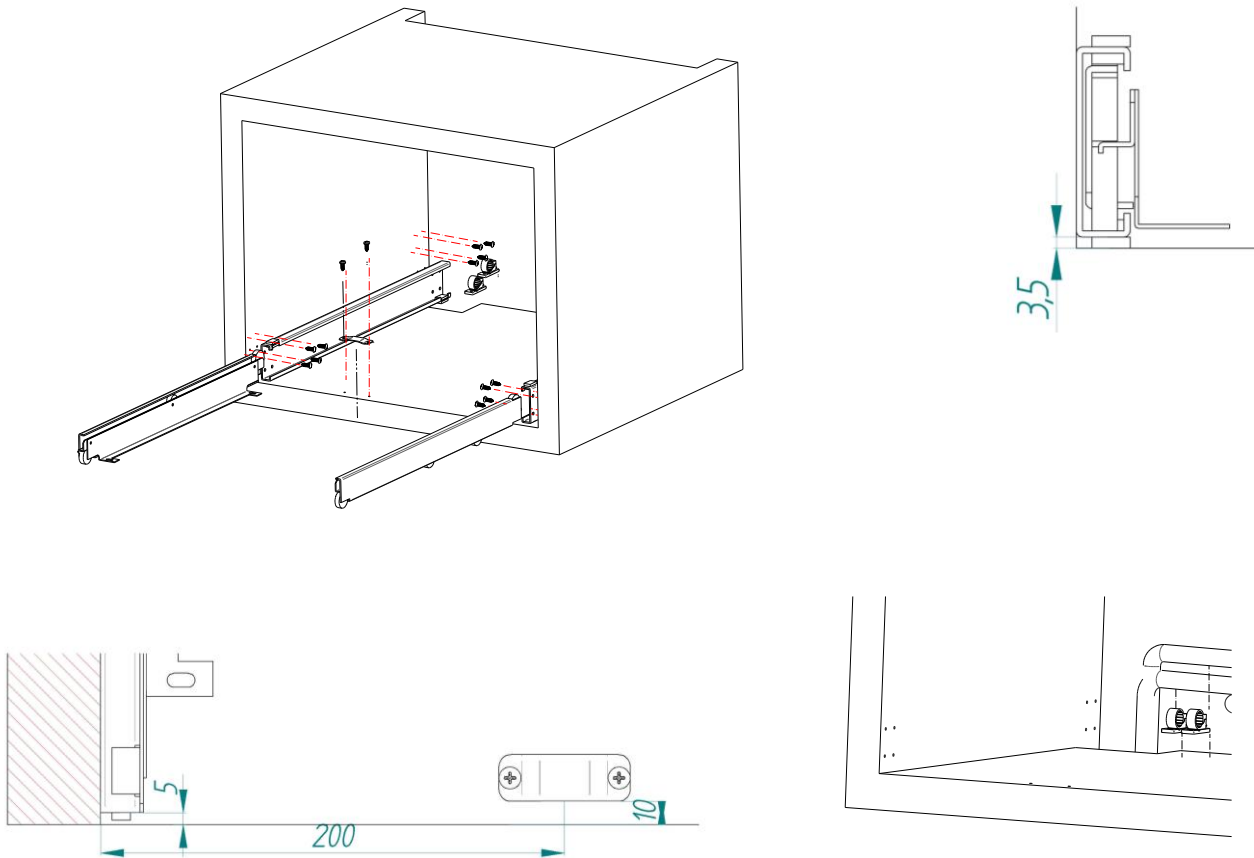

- 2- Screw the machine fixing bridge, like image.
- 3- Screw the clamping flanges of the drain hoses.

- 4- Put the machine on the support angles of the guides. Adjust the width before tightening the screws, checking that it glides smoothly throughout the stroke.

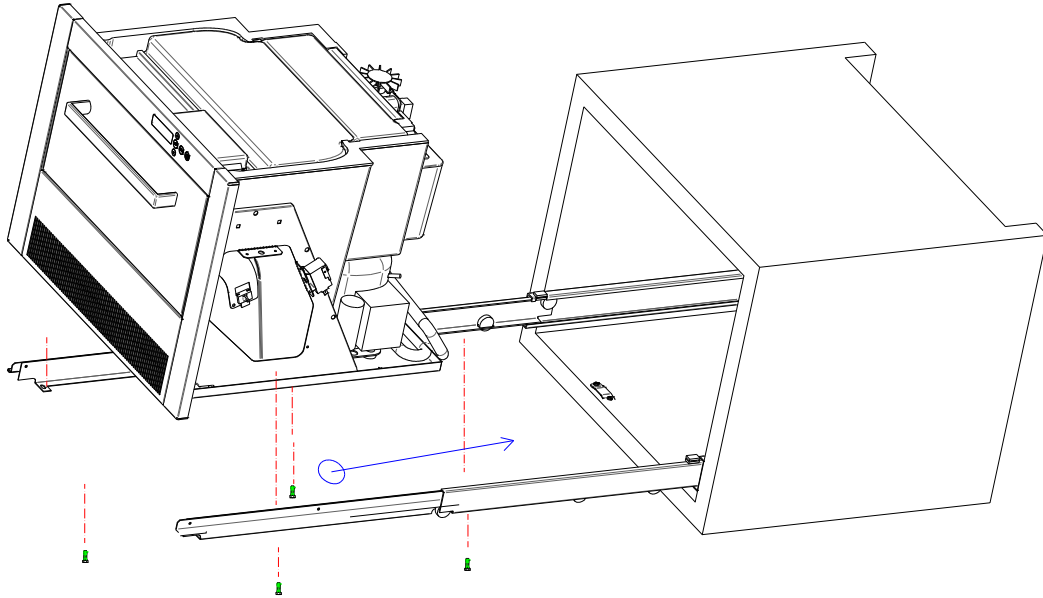

4.4.- Water and drain

The quality of the water supplied to the ice machine will have an impact on the time between cleanings and ultimately on the life of the product. It also Will have a remarkable influence on the appearance, hardness and flavour of the ice.

a) WATER IMPURITY:

The large ones are retained by the filters that accompany each machine. Its cleaning will be periodic depending on the purity of the water. For small impurities we recommend the installation of a 5 micron filter.

b) WATER WITH MORE THAN 1000PPM:

The ice will come out less hard and stick a little in stock. Cubes with white spots may appear. Calcareous deposits will form in the machine that can interfere with its proper functioning. The hardness of the water is corrected with the installation of a good water softener.

c) HIGHLY CHLORINATED WATER:

Ice tastes like bleach (chlorine). A carbon filter can be installed to remove this taste.

Keep in mind that water can be received with all three cases simultaneously.

d) HIGH PURITY WATER:

Production can decrease by up to 10%.

4.4.1 Water supply connection

Use the flexible connection with the two filter gaskets supplied with the machine.

The pressure must be between 1 and 6 Bars

If the pressures exceed these values, install the necessary corrective elements.

Leave the necessary length free to remove the machine to the end of the guides.

The rest can be bridled and collected to the side to prevent the machine from touching the water pump and slowing it down or making noise.

4.4.2 Drain connection

Drainage should be located as below:

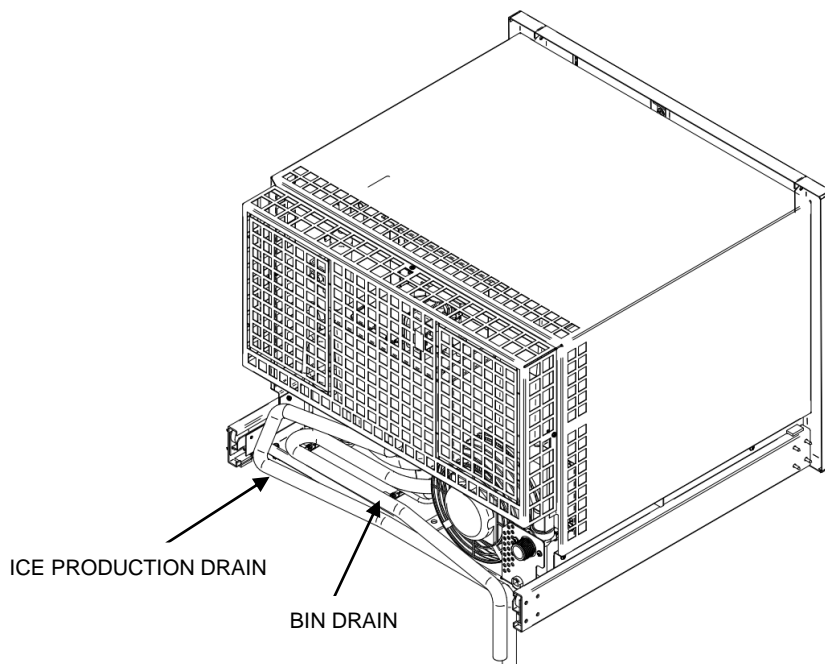

In the left part of the place of the machine and below the lower level of the machine. As is, the piping is flexible and it allow user to put in and take out the

machine from his position.

The drain pipe should have 50mm inner diameter mouth to insert the two machine drain hoses.

Fix the tubes with the supplied flange staples. In this way, we ensure that when the machine is removed and stored, the tubes do not come out.

4.5. – Electric connection

It is mandatory to ground the equipment. To avoid possible electric shock on individuals or damages to the equipment, the machine should be grounded pursuant local and/or national regulations as the case may be.

THE MANUFACTURER SHALL BE HELD HARMLESS IN CASE OF DAMAGES ARISING DUE TO THE LACK OF THE GROUND INSTALLATION.

The machine is supplied with a 1.5 m long cable fitted with a Schuko plug. If the power cord is damaged, it must be replaced with a special cord or assembly to be supplied by the manufacturer or after-sales service.

Prevent the opportune socket outlet.

It is advisable to install a switch that allows the machine to be completely disconnected without removing it.

Voltage is indicated in the nameplate. Variation on voltage above the 10% stated on the nameplate could result on damages or prevent the machine start up.

The line to the base of the plug must have a minimum cross-section of 1.5 mm².

Check that the mains voltage and the indicated voltage are the same.

5. START-UP

Once followed the installation instruction, follow as the next:

- 1) Connect the machine to the water supply.
- 2) Open the water inlet valve and check that there are not leaks.
- 3) Connect the machine to the electrical current.
- 4) Put the machine on “Time” (go to 7.1, [user menú](#) for more informations).

- 5) Turn on the machine with the main interruptor. The display Will turn on and show “Starting” for 30 seconds and then start working with a harvest cycle, the display will show the message “Harvest” 
- 6) Check that there is no element that rubs or vibrates.
- 7) Check that the curtain can be move.
- 8) Check that the injectors send the water to the evaporator following the correct direction during the ice-cycle.
- 9) Once passed 10 minutes, check that the water bin is not leaking from the maximum level spillway.
- 10) Check that when the cycle ends the frost in the suction tube is about 50 mm from the compressor.
- 11) Check that during the fall of the ice, there is no water loss.
- 12) Put the machine in her location. Fix with the anchor screwed and place the front grid. See drawing.

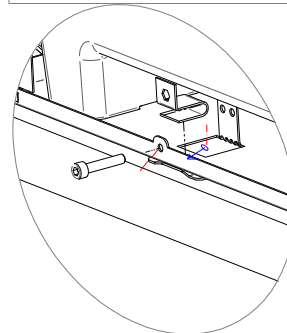
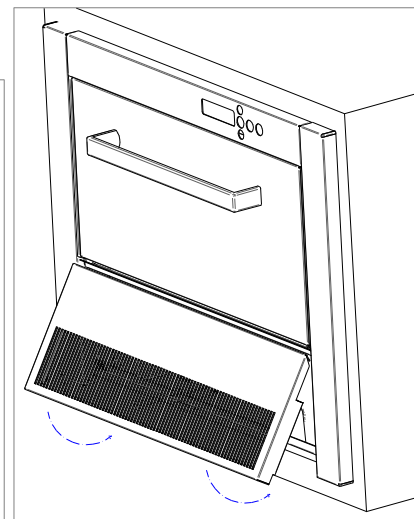
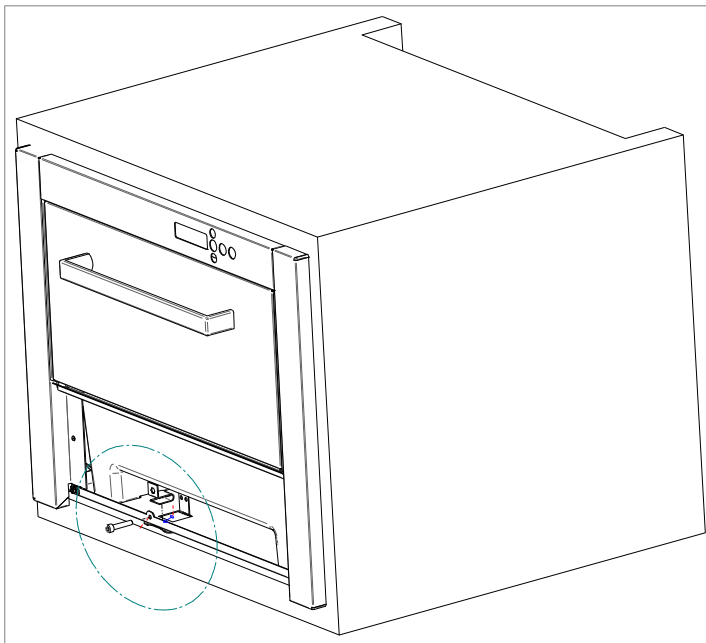

REMOVAL OF THE MACHINE FROM ITS HOUSING SHOULD ONLY BE CARRIED OUT BY THE TECHNICAL SERVICE.

6. MAINTENANCE AND CLEANING PROCEDURES

ATTENTION:
INSTRUCT THE USER ABOUT MAINTENANCE, LETTING THEM KNOW THAT THIS, AS WELL AS THE FAULTS CAUSED BY ITS OMISSION, **ARE NOT INCLUDED IN THE WARRANTY**

Only if well maintained will the machine continue to produce good ice quality and be free from breakdowns.

Maintenance and cleaning intervals depend on the conditions of the site and the quality of the water.

ATTENTION:
At least one check and cleaning should be done every six months.
In very dusty places, condenser cleaning may be necessary every month.

ACTION	MONTHLY	QUARTERLY	SEMIANNUAL	ANNUAL	BIENNAL	T UNIT
Cleaning of air condenser Aire inlet filter	0000	0000	****	****	****	30 minutes
Cleaning of the injectors		####	####	****	****	30 minutes
Cleaning of the ice production circuit		####	####	****	****	45 minutes
Sanitary cleaning		####	####	****	****	30 minutes
Cleaning/change air filters	####	####	****	****	****	30 minutes

Cleaning ice bin	&&&	&&&	&&&	&&&	&&&	--
Exterior cleaning	&&&	&&&	&&&	&&&	&&&	--

0000 Depending on the room conditions.

Depending on the condition and quality of the water.

&&& TO BE CARRIED OUT BY THE USER

**** **INDISPENSABLE**

MAINTENANCE AND CLEANING OPERATIONS AND BREAKDOWNS CAUSED BY THEIR OMISSION: THEY ARE NOT INCLUDED IN THE WARRANTY.

The installer will invoice the travel, time and materials used in these operations.

MAINTENANCE AND CLEANING PROCEDURES.

**** **ATTENTION:** For all cleaning and maintenance operations: disconnect the machine from the electrical power. **

6.1.- Condenser / air filter

- 1) Disconnect the machine.
- 2) Remove the front panel (stretch out the bottom clips).
- 3) Vacuum, wash or replace the filter.
- 4) Remove the lateral panel that cover the condenser.
- 5) If it is necessary to clean the finned area with the help of a vacuum cleaner equipped with a brush, non-metallic brush or low-pressure air.

6.2.- Evaporator / water bin

- 1) Prepare a 50% solution of phosphoric acid and distilled water. Do not use hydrochloric acid. Pour this solution slowly into the top of the evaporator, until it overflows into the vat of water. The mixture is most effective with water between 35°C. and 40°C.
- 2) Let the solution act for 10 minutes.
- 3) Remove the overflow, wait for the water tank to empty. Put the overflow.
- 4) Turn off the water shut-off valve.
- 5) Refill the system to the maximum level of the water tank with the same solution. Connect the machine (the water must be turned off) and wait 20 minutes.
- 6) Turn on the water, connect the machine.

NOW START THE SANITAR CLEANING

- 7) Connect the machine and once it has finished entering water, remove the lid of the evaporator, and pour bleach (a glass) into it. Wait 20 minutes.
- 8) Disconnect the machine and reconnect it, and once the ice has fallen, THROW it away and let the machine do a complete cycle.

ATTENTION: ** Throw away the ice made with this procedure

- 9) Clean and assemble all components, check that the grid is clean and that the ice cubes slide well. Check that the curtain does not get any slats locked. Check and/or change the water inlet filters. CHECK THAT THE INJECTORS ARE CORRECTLY PLACED, THAT THE WATER FANS FORMED BY THEM ARE UNIFORM AND ALL THE SAME. Eventually, disassemble, clean and

place in the right position.

6.3.- Ice bin

- 1) Disconnect the machine, close the water inlet valve and empty the cube container.
- 2) Use a kitchen cloth with detergent.
- 3) If the white lime stains do not go away, rub them with a soft anti-limescale, wait a little and wipe the cloth again. Rinse with plenty of water, dry and start the machine again.

6.4.- External cleaning

Use the same process that the used with the ice bin.

6.5.- Colector e inyectoros

- 1) Remove the curtain. (Take the opportunity to clean it with phosphoric acid, rinse, clean with bleach and rinse under the tap).
- 2) Remove the ice drop grid. (Clean it just like the curtain) PULL UP THE MANIFOLD-IT IS PRESSURE MOUNTED
- 3) Remove the injectors and manifold covers, clean them.
- 4) Disassemble and clean the main filter from the head. (IT IS PRESSURE MOUNTED)
- 5) Assemble filter, injectors and manifold.

ATTENTION

IT IS VERY IMPORTANT, WHEN PUTTING THE COLLECTOR BACK IN, THAT THE INJECTORS ARE COMPLETELY PERPENDICULAR TO IT, IF THE END CUBES ARE CROOKED, THEY CAN RUN OUT OF WATER.

- 6) Assemble the ice cube ejector grid. (ATTENTION: It must be locked in the later headframes.

- 7) Assemble the curtain. Make sure that ALL the slats move freely.
- 8) Start the machine and THROW THE FIRST BATCH OF ICE.

6.6.- Filters cleaning

They tend to get clogged the first few days after the machine is running, ESPECIALLY WITH NEW PLUMBING INSTALLATIONS.

Release the hose and clean them under the running water.

6.7.- Water leakage checking

Whenever the machine is intervened, check all the water connections, the condition of the clamps and hoses in order not to leave leaks and prevent breakages and floods.

7. CONTROL BOARD

This machine is powered by the Digital Electronic Controller adapted for ITV GALA-DELTA cubed ice makers.

On the front of the machine, we can see the display and the button panel, through it we will access the different menus, in which we can move to consult and configure the working values.

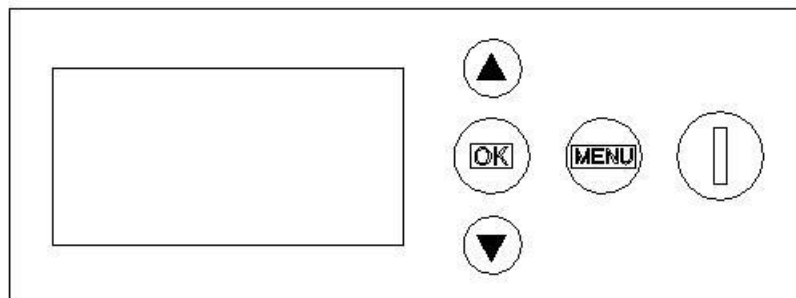

7.1.- User menu

It can be accessed with the machine turned off by simply pressing the "MENU" button once.



Principal menu

1. Set time
2. Timer
 - A. ON
 - B. OFF
3. N° of cubes
 - a. Endless
 - b. 24
 - c. 48
4. Cube dimension
5. Language
 - a. English •
 - b. Español
 - c. Nederlands
 - d. Italiano
 - e. Deutsch
 - f. Francais

1. Set time

It will show the time that the machine has flashing the values that can be modified, with the up / down arrows we will adjust the values and when you put the desired press OK.



2. Time

As default, the machine show "OFF", active it with the arrow and then "OK".

3. N° of cubes

Por defecto continuo, podemos elegir la cantidad de ciclos antes de que pare la maquina

4. Cube dimension

As default: 5, increase or decrease size with the arrows and OK in the desired size.

5. Language

As default: English. Choose language with arrows and OK on the desired.

To exit press *Menu*.

The values used are kept stored in the following switch-ons, (without power cuts)

7.2.- Installator menu

It is accessed with the machine by pressing for 10 seconds the three buttons dates up + down + OK.

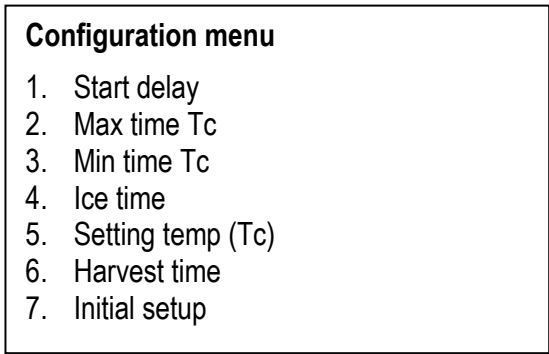

1. Start delay

The start-up time marks the time the machine must wait until the compressor, fan, pump and other outputs start.

To modify: Up/Down Arrows – OK

2. Max time Tc

The maximum time measures the maximum time it should take to reach the setting temperature.

To modify: Up/Down Arrows – OK

3. Min time Tc

The minimum time measures the minimum time it should take to reach the setpoint temperature

To modify: Up/Down Arrows – OK

4. Ice time

The manufacturing time will control the manufacturing time of the machine from the time it reaches the setting temperature until the start of take-off. The controller will recalculate this time based on the ambient and water temperatures.

To modify: Up/Down Arrows – OK

5. Setting temp (Tc)

It is the temperature at which the manufacturing time begins to be counted.

To modify: Up/Down Arrows – OK

6. Harvest time

The take-off time will mark the seconds that we want the take-off to last. The controller will recalculate this time based on the ambient and water temperatures.

To modify: Up/Down Arrows – OK

7. Inicial setup

This option will return all machine parameters to a standard factory setting. Pressing both arrows, it will ask if we are sure to put all the parameters by default and we will select between the options "OK or MENU". In the case of selecting OK, all the default options will be applied and you will return to the Settings Menu and in the case of pressing MENU, you will exit this option without making any changes.

Setup	
Start delay	45seg
Max time Tc	60m
Min time Tc	4m
Ice time	25m
Setting temp	- 4°C
Harvest time	1m 50seg

7.3.- Information menu

It can be accessed at any time (on or off) by pressing the MENU key 10". This menu gives us information on the operation of the machine, possible breakdowns, duration of last processes, temperature.

Menú Información
1. Tamb / Tcyc
2. Ice T. / Cyc. T.
3. Cool T / Hrv. T.
4. Input / Output

1. *Tamb / Tcyc*

It shows us the values that are being recorded, the ambient probe, the temperature of the air that enters, the cycle, the temperature at which it is, where the ice is manufactured, in both records, in case of breakdown of them they will show us "*****".

2. *Ice time / Cyc. T.*

Ice time, gives us the time spent in the last cycle from the time the setpoint temperature is reached until take-off begins.

Tcyc, gives us the sum of the manufacturing time plus the take-off time.

3. *Cool T. / Hrv. T.*

Cool T., shows us the time it takes to reach the setpoint temperature from the end of take-off.

Hrv. T., during take-off and cool-down, gives us the time it took on the last take-off. During manufacturing it will show us a countdown indicating the time to reach the next take-off.

4. *Input (I) / Output (O)*

It shows us the information that outputs and inputs are activated by empty boxes without signal or filled with signal (like picture).

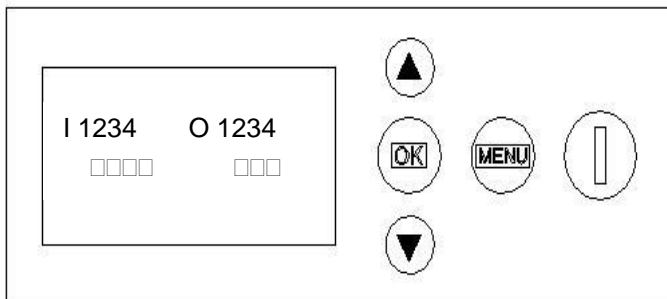

Input	
Stock thermostat	1
Security thermostat	2
Flood	3
Free	4
Output	
Compressor / Ventilator	1
Pump	2
Valves	3
Free	4

8. DISPLAY'S ALARMS

Alarm	Probable cause	Comprobación	Solution
<i>Full stock</i> ----- <i>Machine doesn't work</i>	Thermostat error	In the bin stock, the ice cubes do not touch the thermostat rod	Check the stock thermostat
<i>T cycle</i> ----- <i>Machine doesn't work</i>	Deteriorated cycle probe	Tamb "*****" in the information menu	Change the cycle probe or change it for the room probe, the machine still working as is as if the environment were 20°C.
<i>High temperature</i> ----- <i>Machine doesn't work</i>	High Security Pressure Switch	Check the ventilator or compressor	Change the High Security Pressure Switch
	Lack of ventilation	There are objects that stops the inlet valve in the machine	Remove these objects
		Dirty ventilation filter	Wash in water
		Dirty condensator	Clean the condenser
<i>Too short time</i> ----- <i>Machine doesn't work</i>	Ice blocks forming in the machine	Check the condensation and the pressure of the inlet water	
	Showers do not water	The pump doesn't works	Change the pump
		Loose Discharge Tube	Tighten the tube at its joints
<i>Too long time</i> ----- <i>Machine doesn't work</i>	Compressor or ventilator doesn't work	Information menu output 1 signal in the information menu during ice production	Change the broken parts
		Fan with improperly positioned blades	Reposition the blades
	Hot gas valve	Don't close	Change the valve
	Low cooling performance	Check the Refrigeration circuit	
	Water leakage	Check the inlet valve	Change the broken parts
	Lack of ventilation	Like as high temperature	Like as high temperature
Little or no passage of recommended air vents		Increase air vents or make them if you don't have them	

9. USER TROUBLESHOOTING GUIDE

Problem	Probable cause	Correction
None of the electrics work.	The machine is not plugged in	Plug the machine and verify socket power
	The line fuse is blown or the circuit breaker or differential disconnected	Replace the fuse or reset.
	The power supply is incorrectly connected or in poor condition	Check connections and supply cable
	Stop thermostat incorrectly set or defective	Check and adjust or replace
All the electrical parts work but not compressor.	Loose wire	Check connections
	Compressor relay defective	Change the relay
	Klixon defective	Change Klixon
	Compressor defective	Change compressor
All electrical parts are working. The compressor clicks.	Low voltage	Check voltage and lines
	Dirty condenser	Clean
	Faulty or blocked air circulation	Improve air circulation
	Fan defective	Change ventilator
	Defective compressor electrolytic condenser	Change
	Water pressure valve incorrectly set or defective	Adjust or change
Everything seems to be working fine, but no ice is produced in the evaporator.	Non-condensable gases in the system	Vacuum and charge gas
	Bomba descebada.	Check the overflow, that the water tank does not leak, that the water inlet valve is in good condition and prime the pump.
	Failed pump	Change the pump
	No water entering the tank	Check water inlet solenoid valve and replace if necessary
The water bin runs out of water	Check the overflow and an eventually water leakage	

	Humidity in the system	Change the dehydrator, vacuum and charge
	Inefficient cooling system. (Dirty condenser, Pressure switch or condensation water inlet valve damaged or poorly regulated or lack of refrigerant.	Check the components and the system
For further problems call aftersales service		

Cubes form, but do not detach.	Dirty water inlet filters	Clean filters
	Low water pressure	Increase the pressure (sometimes the problem is solved by removing the flow meter from the water inlet valve).
	Fan or condensing water pressure switch too low or broken.	Adjust or replace
	Ambient or water temperature below 7°C	Increase takeoff time
	Programador averiado.	Revisar y eventualmente cambiar.
	Ice time too long. The cubes have chips outside the mold.	Adjust by reducing cycle thermostat time.
	Hot gas valve defective or incorrectly connected	Check and possibly change
Low ice production	Dirty condenser, obstructed air circulation or hot air is received from another appliance	Clean condenser, release air circulation or change the location of the machine
	Defective hot gas valve, always lets some hot gas through (tube temperature is an indication).	Replace the hot gas valve
	Fan pressure switch or condensing water inlet valve set too low or defective.	Adjust or replace
	Refrigerant charge too high or too low.	Adjust the load
	Water inlet valve does not close (leaks).	Check and replace if necessary
	Compressor ineffective.	Change the compressor
Empty cubes, with irregular and very white edges	Loss of water in the water tank during the cycle.	Eliminate water leakage
	Clogged injectors	Clean injectors.

	Curtain slats do not close tightly, lock up and water is lost	Adjust the curtain slats or clean the shaft (it may have scale that prevents the slats from turning smoothly).
The machine does not stop, even if it is full of ice cubes	Poorly regulated or defective stock thermostat	Adjust and/or change.
The cubes are melted in the stock tank	Obstruction in the drainage of the machine or in the drainage of the installation	Unblock