



TECHNICAL MANUAL

IQ R290 RANGE

MODELS:

- IQ 50C
- IQ 90C
- IQ 180C
- IQ 230
- IQ 450
- IQ 650

READ THIS MANUAL CAREFULLY, ESPECIALLY THE INSTALLATION AND MAINTENANCE SECTIONS. THE INSTALLATION OF THIS APPLIANCE MUST BE CARRIED OUT BY THE TECHNICAL ASSISTANCE SERVICE.

INDEX

1. INTRODUCTION.....	4
1.1. WARNINGS	4
1.2. MACHINE RECEPTION	6
2. INSTALLATION	8
2.1. ICE MACHINE LOCATION	8
2.2. ICE MACHINE LEVELING	9
2.4. MINIMUM DISTANCE TO OBSTACLES.....	9
2.5. WATER SUPPLY CONNECTION	10
2.6. DRAIN CONNECTION.....	11
2.7. ELECTRIC CONNECTION	11
3. PRIOR CONTROL AND START-UP.....	12
3.1. PRIOR CHECK.....	12
1.2. ASSEMBLY OF THE DISPERSION CONE	12
3.3. START UP.....	13
4. DESCRIPTION OF COMPONENTS	14
4.1 REFRIGERATION EQUIPMENT	14
4.2 HYDRAULIC EQUIPMENT	15
5.2.1 Hydraulic system compact machine	15
5.2.2 Modular machine hydraulics	16
5.2.3. Drainage	16
5.2.4 Water level control.....	17
4.3 ELECTRICAL EQUIPMENT	18
.....	18
5. SEQUENCE OF OPERATION	22
7-ALARMS	23
7.1 MAGNETO-THERMAL PROTECTOR OR CIRCUIT BREAKER	23
7.2 THERMAL PROTECTOR OF THE GEARED MOTOR.....	23
7.3 WATER LEVEL.....	23
7.4 STOP DUE TO ICE FILLING	23
8. MAINTENANCE AND CLEANING PROCEDURES.....	24
8.1 CLEANING OF AIR CONDENSER	25

8.2 CLEANING OF WATER CONDENSER25

8.3 CHANGE OF WATER FILTER.....25

8.4 CLEANING THE HYDRAULIC CIRCUIT:.....25

8.7 MAINTENANCE TABLE28

9. TROUBLESHOOTING GUIDE.....29

10. OTHER TECHNICAL INFORMATION.....31

1. INTRODUCTION

This manual has been created to provide the installer with information to carry out a correct installation and for the effective maintenance of the machine.

Furthermore, the user will find in the document a section referring to the cause of possible incidents, as well as complete information on their resolution.

Therefore, it is recommended to keep the manual in a safe place to resolve any questions related to the operation of the machine during its useful life.

1.1. WARNINGS

- The installation of this equipment must be carried out by the Technical Service.
- Connect only to a drinking water distribution network.
- Use the new hoses supplied with the appliance. Old hoses must not be reused.
- The socket must always be located in an accessible place.
- When positioning the appliance, make sure that the power cord is not trapped or damaged.
- Do not place multiple portable power outlets or portable power sources at the rear of the appliance.
- Always disconnect power to the machine before any cleaning or maintenance service.
- Any necessary change in the electrical installation for the proper connection of the machine must be carried out exclusively by qualified and certified professional personnel.
- Modifying or attempting to modify this machine is extremely dangerous and will void the warranty.
- The appliance must not be used by persons (including children) with reduced physical, sensory or mental capabilities, or lack of experience and knowledge, unless they have been given supervision or instruction.
- Connect only to potable water supply. This machine is not intended to be used outdoors or exposed to rain.
- The machine must be connected using the power cord supplied with the equipment. It is not intended to be connected to a fixed pipeline.
- To avoid danger due to instability of the appliance, it must be fixed in accordance with the instructions.

If the power cable is damaged, it must be replaced with a special mounting cable that will be supplied by the manufacturer or after-sales service. This replacement must be carried out only by a qualified technical service.

It is mandatory to connect the equipment to ground to avoid possible electric shocks to people or damage to the equipment. The machine must be grounded in accordance with local and/or national regulations. The manufacturer disclaims any responsibility in the event of damage occurring due to the lack of ground installation.

To ensure the proper functioning and efficiency of this equipment, it is very important to follow the manufacturer's recommendations, especially those related to cleaning and maintenance operations, which must only be carried out by qualified personnel.

ATTENTION: The intervention of unqualified personnel, in addition to being dangerous, can cause serious breakdowns. In case of damage, contact your dealer. We recommend always using original spare parts.

ITV reserves the right to make changes to specifications and design without notice.

WE REMIND YOU THAT MAINTENANCE AND CLEANING OPERATIONS ARE NOT INCLUDED IN THE WARRANTY AND THEREFORE, THEY WILL BE BILLED BY THE INSTALLER.

This sign indicates "Risk of Fire/Flammable Materials" due to the use of flammable refrigerant.



For this reason, the following warnings should be considered:

Keep the openings for ventilation of the appliance casing or built-in furniture without obstructing it.

- Do not use mechanical devices or other means to accelerate defrosting, only those recommended by the manufacturer.
- Do not damage the refrigerant circuit.
- Do not use electrical devices inside the food compartments, unless they are recommended by the manufacturer.
- Explosive substances, such as aerosols with flammable propellant, must not be stored in this appliance.

In case of refrigerant leak:

- Do not generate a flame in the surroundings of the appliance.
- Do not turn on/off switches or connect/disconnect plugs in the area of the appliance.
- Do not use a direct flame.
- Immediately ventilate the area of the appliance by opening doors and windows.
- Call an authorized technical service.

Disposal of the ice machine: ITV encourages you to follow the regulations of each country regarding the ecological disposal of electrical and electronic devices such as this. The user who wants to dispose of this equipment must contact the manufacturer and follow the appropriate differentiated collection method for subsequent treatment.

1.2. MACHINE RECEPTION

Inspect the outer packaging. In case of damage, make the corresponding claim to the carrier. To confirm the existence of damage, unpack the machine in the presence of the carrier and note any damage to the equipment on the receipt document or transport document.



Always indicate the number and model of the machine. This number is printed in three places:

- (1) Packaging: On the outside it contains a label with the serial number.



- (2) Exterior of the unit: On the rear panel of the unit there is a label with the same characteristics as the previous one.

- (3) Nameplate: On the back of the machine.

ITV Ice Makers <small>ESB40632291</small>		S/N: 2308000824762	
		<small>CD: 9133U</small>	
ICE QUEEN IQ90C A 220/50 R290			
<small>Volt.</small> 220-240 ~	<small>Ph.</small>	<small>Hz.</small> 50	<small>A.</small> 2.6
<small>Ref.</small> R290	<small>g.</small> 110	<small>w.</small> 470	<small>clas.</small> 5
<small>condensacion-condensation-kondensation</small> Aire-Air-luft		Made in Spain/EU	
<small>Insulation Blowing gas: HFO-1336mzz / HFO-1233zd</small>		<small>08-23</small>	
CE EAC			

Check that the installation kit inside the machine is complete and includes:

- Shovel
- ¾ inch water inlet hose
- 22mm drain hose
- Filter gasket
- User manual
- Warranty

CAUTION: All packaging elements (plastic bags, cardboard boxes and wooden pallets) must be kept out of the reach of children, as they are a source of potential danger.

2. INSTALLATION

2.1. ICE MACHINE LOCATION

This ice maker is not designed to be used outdoors. The ice maker should not be located next to ovens, grills, or other equipment that produces a lot of heat.

Compact IQ machines are designed to operate at ambient temperatures between 10°C and 43°C (50°F and 109°F) and inlet water temperatures between 5°C and 35°C (41°F and 95°F).

Below the minimum temperatures there may be some difficulties in making the ice flakes. Above the maximum temperature, compressor life is shortened and output is substantially lower.

Airflow on compact air-cooled machines enters through the front grille, entering the right front, and exiting the left front and rear. In addition, the unit is equipped with a rear ventilation grill. Do not obstruct the front grill with any object.

The unit can run recessed, but with reduced output.

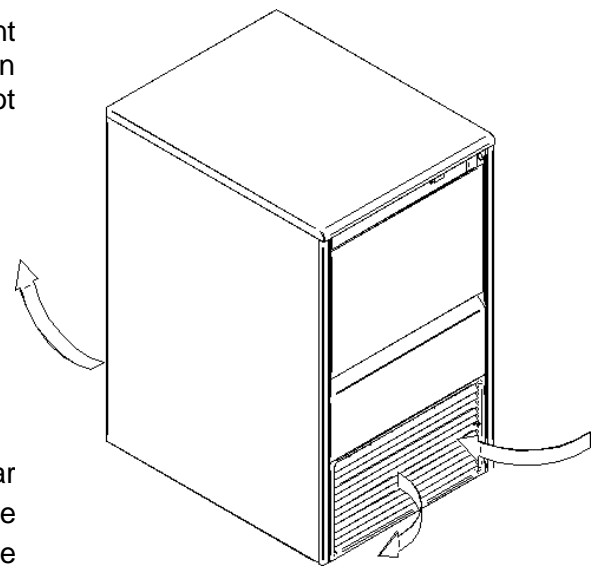
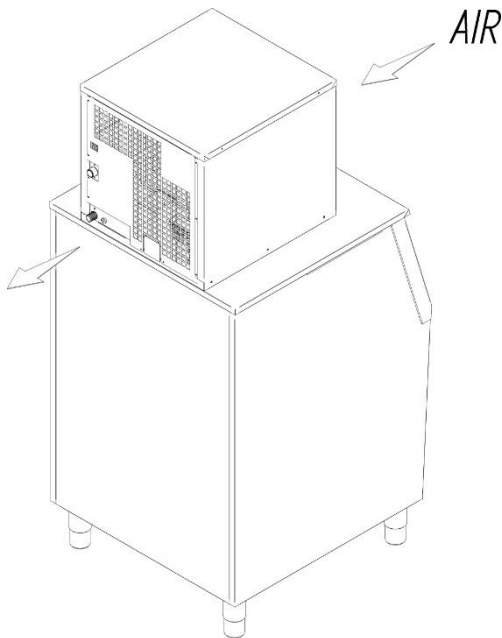

For modular units, the position that the airflow should flow through the rear should be taken into account. Do not place objects behind or in front of the front grill.

If the frontal ventilation is not sufficient, the outlet is totally or partially obstructed or due to its location it receives hot air from another appliance, we recommend, if it is not possible to change the location of the machine, **INSTALLING A CONDENSED MACHINE BY WATER.**

IT IS IMPORTANT THAT THE WATER PIPES DO NOT PASS NEAR HEAT SOURCES SO AS NOT TO LOSE ICE PRODUCTION.

The location should allow sufficient clearance for the water, drain, and electrical connections at the rear of the icemaker.

2.2. ICE MACHINE LEVELING

Use a level on the top of the ice maker to ensure the equipment is perfectly level.

Screw the leveling feet into the bottom of the ice maker as far as they will go. Place the machine in its final position.

Use a level on top of the ice maker. Adjust each leg as necessary to level the ice maker from front to back and side to side..

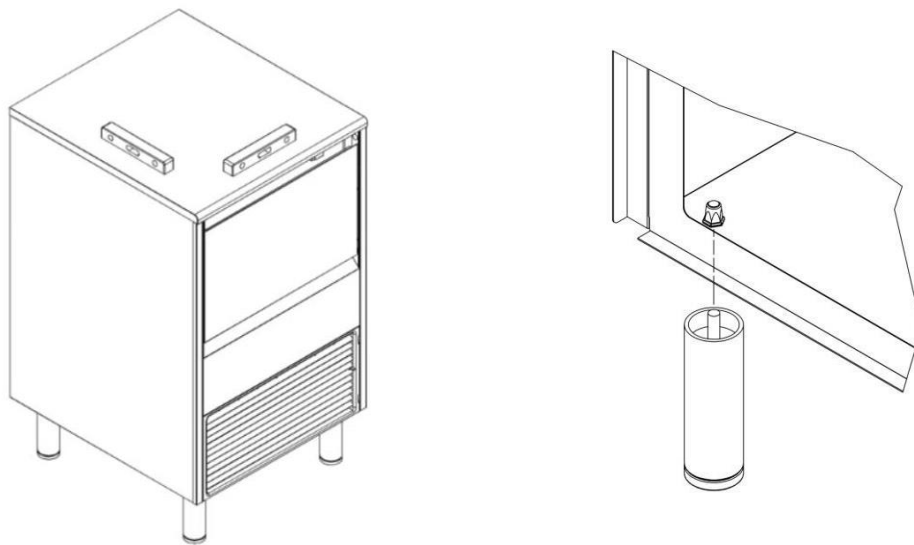

In modular machines, it must be leveled by adjusting the depósito legs.

2.4. MINIMUM DISTANCE TO OBSTACLES

See below for recommended minimum distances for proper operation and efficient service.

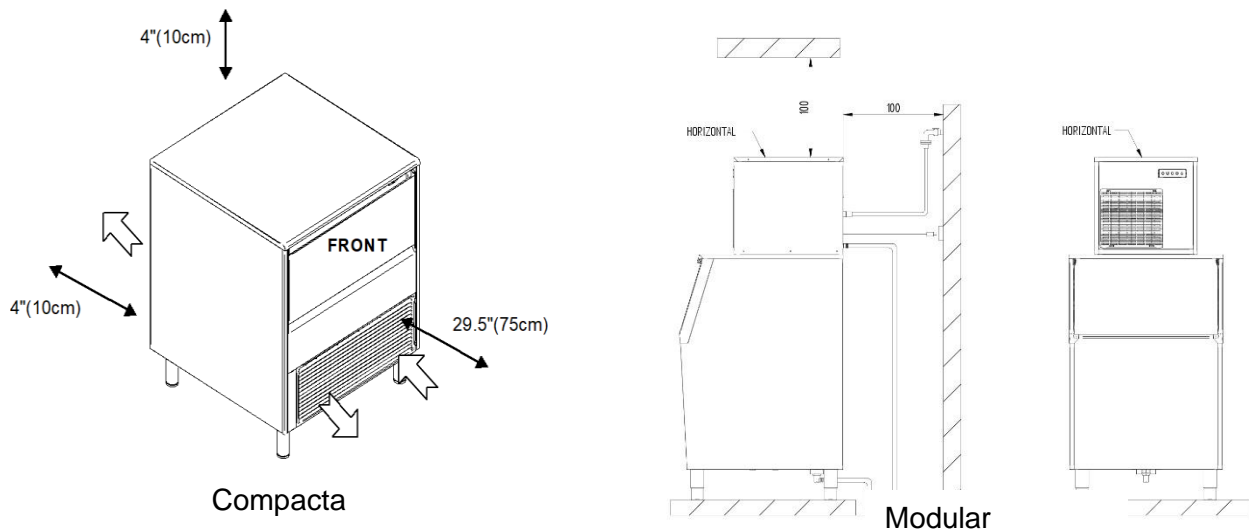

Connection diagram:

The location should allow sufficient clearance for water drainage and electrical connections at the rear of the ice machine.

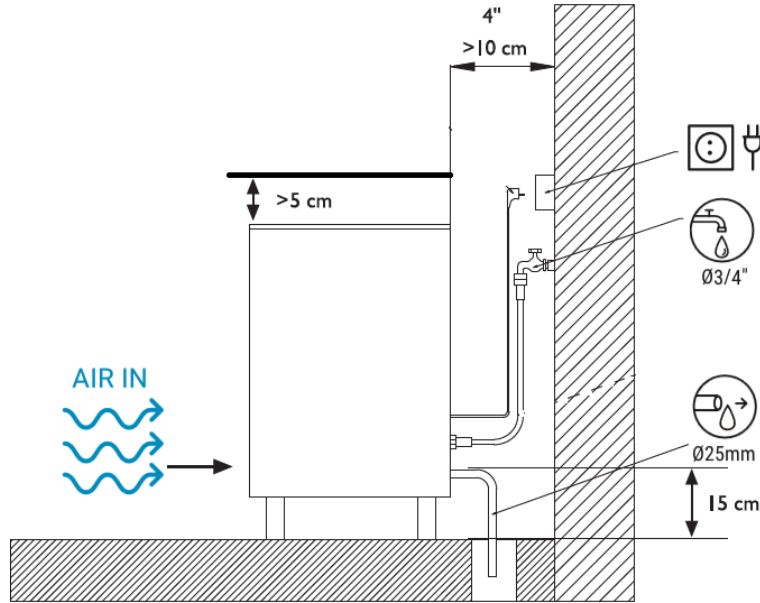

2.5. WATER SUPPLY CONNECTION

The quality of the water supplied to the ice maker will influence the time between cleanings and ultimately the life of the product (mainly on water-cooled units). It will also have a notable influence on the appearance, hardness and flavor of the ice.

Local water conditions may require water treatment to inhibit scale formation and improve flavor and clarity. If you are installing a water filtration system, refer to the installation instructions supplied with the filtration system.

The pressure must be between 0.1MPa and 0.6MPa (1 and 6 bar). If the pressure exceeds these values, install a pressure regulator.

The water connection must be dedicated (only equipment hooked to the water line).

ATTENTION: The machine must be connected to the pipeline with adequate backflow protection in accordance with current national and local regulations.

2.6. DRAIN CONNECTION

The drain must be located lower than the level of the machine, at least 150mm.

It is advisable that the drain hose be 30mm in inner diameter and with a minimum slope of 3cm/meter.

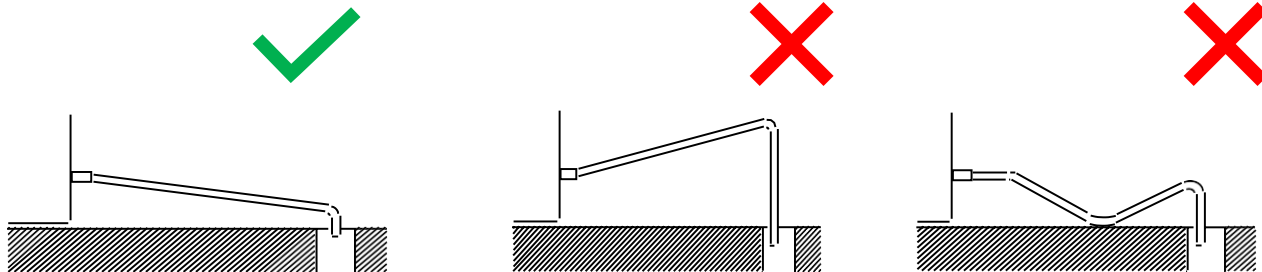

2.7. ELECTRIC CONNECTION

- It is mandatory to connect the equipment to ground. To avoid possible electric shock to persons or damage to the equipment, the machine must be grounded in accordance with local and/or national regulations, as applicable.
- The manufacturer disclaims any responsibility in the event that damage occurs due to the lack of ground installation.
- If the power cable is damaged, it must be replaced with a special mounting cable that will be supplied by the manufacturer or by the after-sales service. This replacement must be carried out only by a qualified technical service.
- The machine should be positioned so that there is a minimum of space between the back and the wall to allow easy and safe access to the cord plug.
- It is advisable to install a remote switch to completely disconnect the machine.
- Protect the outlet. Install appropriate switches, fuses and differential protector.

ATTENTION: The device requires an independent power supply of adequate capacity. Consult the electrical specifications on the nameplate. Failure to use a separate power supply of adequate capacity may result in damage to internal components or wiring. This could cause heat generation or fire.

The voltage is indicated on the nameplate and in the technical specifications section of this manual. A voltage variation greater than 10% indicated on the nameplate may cause damage or prevent the machine from starting.

3. PRIOR CONTROL AND START-UP

3.1. PRIOR CHECK

- a) Is the machine level?
- b) Do the voltage and frequency match those on the nameplate?
- c) Are the drains connected and working?
- d) Are the ambient temperature and water temperature maintained in the following range?

	ATMOSPHERE	WATER
<i>MAXIMUM</i>	43°C/109.4°F	35°C/95°F
<i>MINIMUM</i>	10°C/50.0°F	5°C/41°F

- e) Is the water pressure adequate?

<i>MINIMUM</i>	0.1MPa (1 bar)
<i>MAXIMUM</i>	0.6 MPa (6 bar)

- f) The conductivity of the water must be at least 10 microSiemens

NOTE: In case the inlet water pressure is greater than 6 bar, install a pressure reducer.

Safety check

1. Close the water stopcock. Observe how the level in the float bowl drops.
2. When the water level is low, the machine must be stopped.
3. Open the water stopcock. The level will rise in the float bowl and the machine will start after a time delay of 10 minutes.

1.2. ASSEMBLY OF THE DISPERSION CONE

This accessory distributes the ice in the depósitos, and prevents it from caking under the outlet tube. By varying your position you can direct the ice in any direction.

Anchor to the bottom of the bin cap.

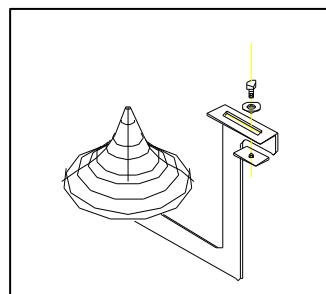

3.3. START UP

Once installation instructions have been followed (ventilation, site conditions, temperatures, water quality, etc.), proceed as follows:

1. Remove the top cover
2. Open the water inlet, check that there are no leaks and that the water level is correct.
3. Turn the switch on the electrical panel to the OFF position.
4. Check that there are no air bubbles in the water supply pipe (from the water tank to the evaporator).

ATTENTION: check that the mains voltage and frequency match those marked on the nameplate.

1. Turn the switch to the ON position. All elements of the machine should now operate except the fan (air condensed machines), which will start when the HIGH pressure rises. The lights, except for the GREEN power input light, should be off. If this is not the case, see the REGULATION AND INCIDENTS sections.
2. Check that the fan blades do not rub and that no pipes in the refrigeration system vibrate.

Damage due to lack of maintenance and cleaning operations is not covered by the warranty.

4. DESCRIPTION OF COMPONENTS

4.1 REFRIGERATION EQUIPMENT

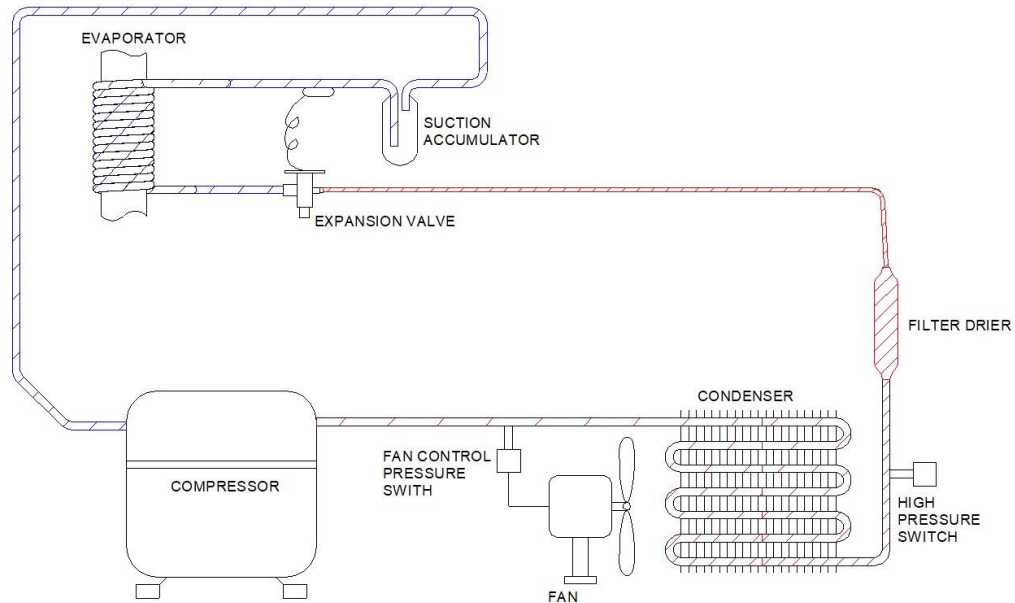

It consists of the following components:

- Compressor.
- Condenser. Air or water.
- Evaporator. Vertical tube with cooling jacket. They are kept filled with water and, inside, a worm screw scrapes and removes the ice that forms.
- Thermostatic expansion valve (capillary in smaller models).
- Dehydrator
- Safety pressure switch (high pressure). Stops the machine, in case a pressure higher than this value is reached:
 - o R290 → OFF 25 bar (362 psi)
- Condensing pressure switch. Controls the fan (air condensation) or valve (water condensation) to keep the high pressure at the stipulated level:
 - o R290 → OFF 11.5 - ON 13.5 bar (167- 196 psi).

4.2 HYDRAULIC EQUIPMENT

- **Water inlet valve.** Controlled by the control board; supplies water from the tank.
- **Water tank/basin.** Maintains the water level inside the evaporator using the communicating vessels principle. Stainless steel electrodes signal the control board to maintain the internal level. An overflow allows drainage to prevent internal spillage in case of malfunction and serves as a drain plug for the tank.
- **Evaporator feed pipe.** Connects the water tank to the evaporator. Diverts to a drain valve that allows the system to be drained.
- **Discharge pipe.** Carries the ice from the evaporator outlet to the ice box.
- **Solenoid drain valve (for compact machines only):** Controlled by the control board; supplies water from the tank..

5.2.1 Hydraulic system compact machine

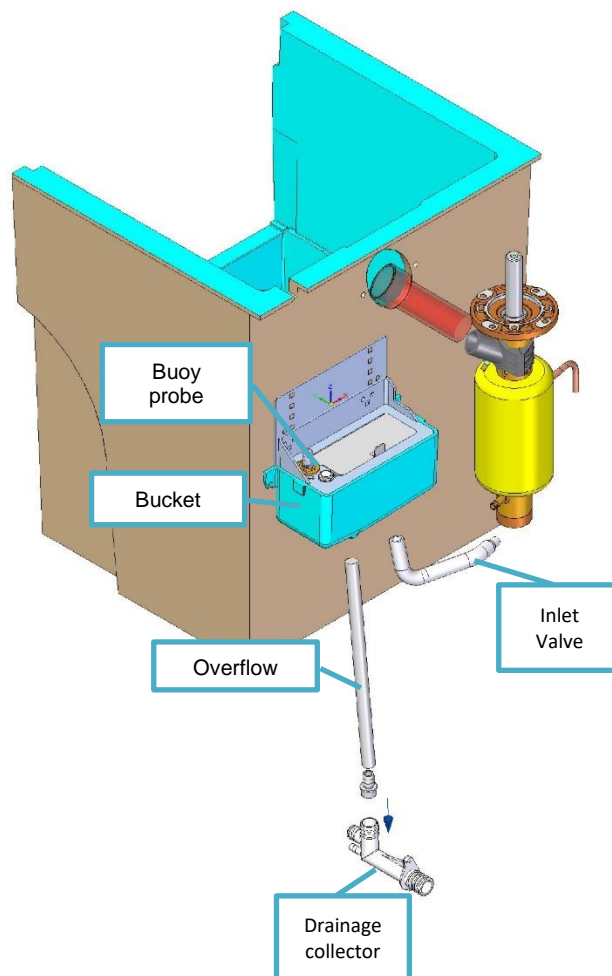

5.2.2 Modular machine hydraulics

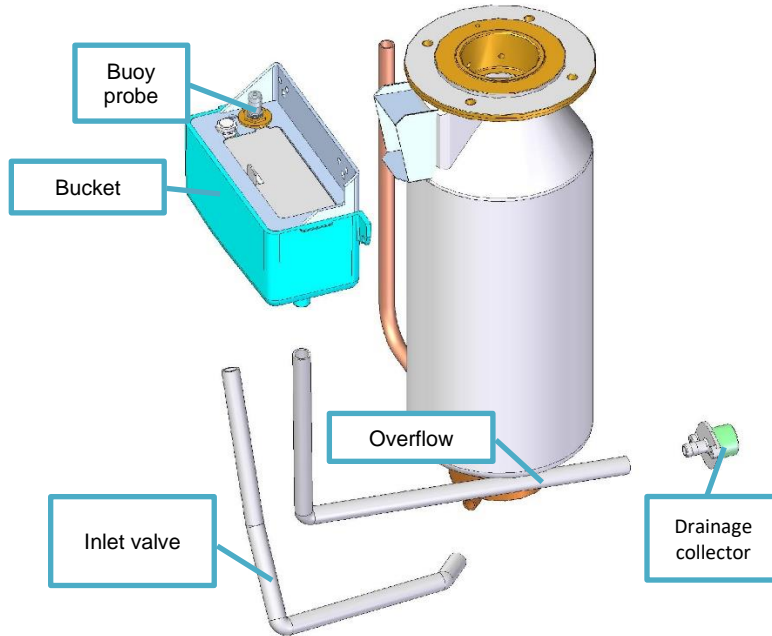

5.2.3. Drainage

While the machine is on, there is water that needs to be evacuated by gravity:

- melt water from the ice melting in the ice bin.
- water from the drain valve that empties the system.
- water from the possible outlet of the safety overflow.

5.2.4 Water level control

The function of the water level is to maintain the necessary flow of water in the evaporator and, with the incorporated micro-magnet, to stop the operation of the machine until the water reaches the tank again.

The optimum level is located on the horizontal line indicated in the figure, and its regulation is carried out following the indications in the figure.

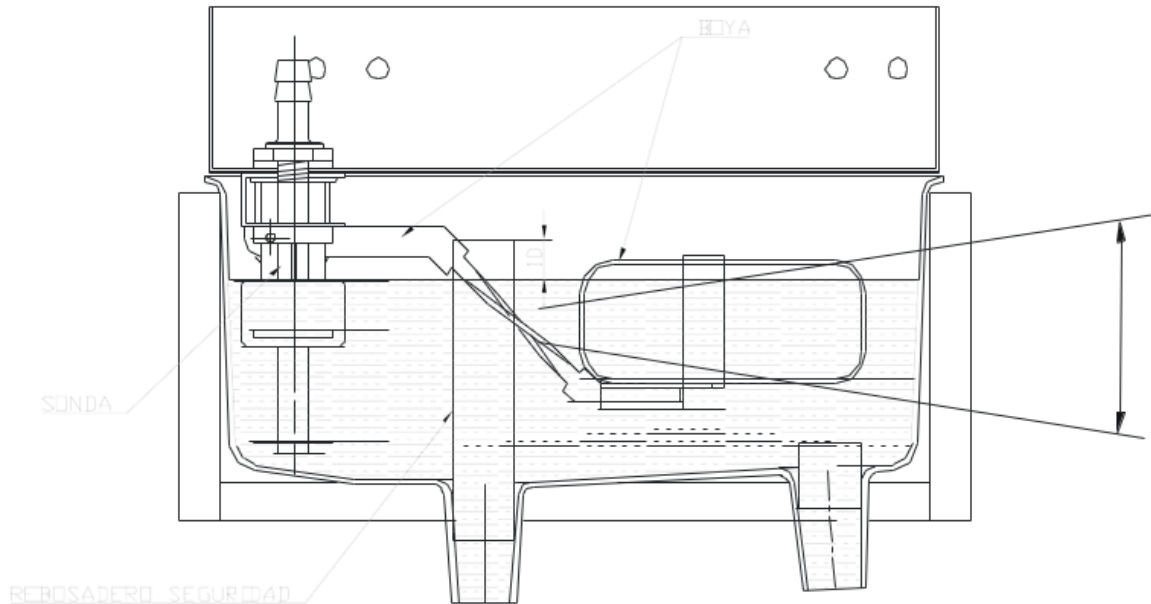

WARNING: Bend upwards to raise the level and downwards to lower it (hold only by the metal arm, never by the buoy).

4.3 ELECTRICAL EQUIPMENT

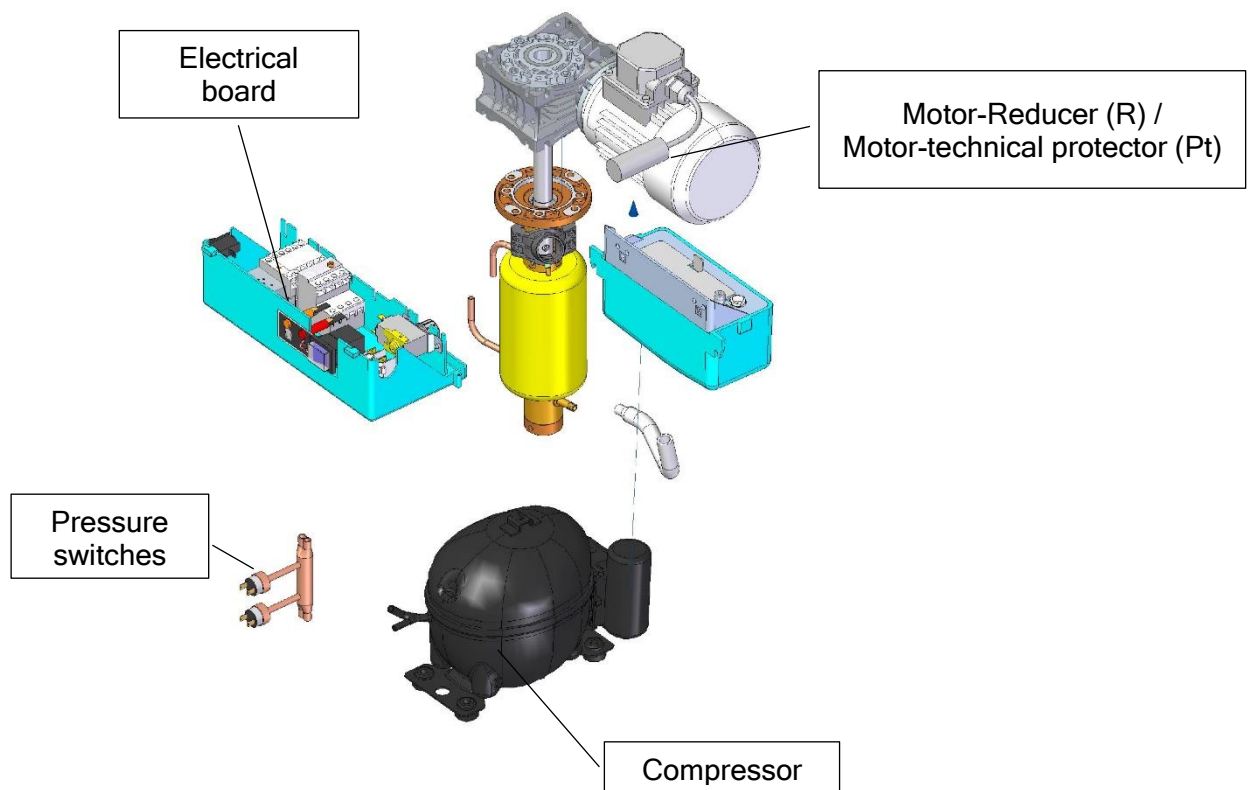

- **Geared motor (R):** is a mechanical assembly consisting of an electric motor coupled to a speed reducer. They reduce the input speed and multiply the torque based on the gear ratio "i".
- **Compressor (C) :** A compressor is a thermal machine designed to increase the pressure of certain types of fluids called compressible fluids, such as gases and vapours.
- **Switch panel exterior:** Located on the front of the machine, it has the power button and indicator lights.
- **Safety pressure switch (Pt):** If the set pressure (25 bar) is reached, it stops the machine completely and sets it in alarm.
- **Condensing pressure switch (Pc) :** Starts or stops the fan or water inlet to maintain the set high pressure.

WIRING DIAGRAM COMPACT MACHINE

IQ 50-85 esquema eléctrico - wiring diagram

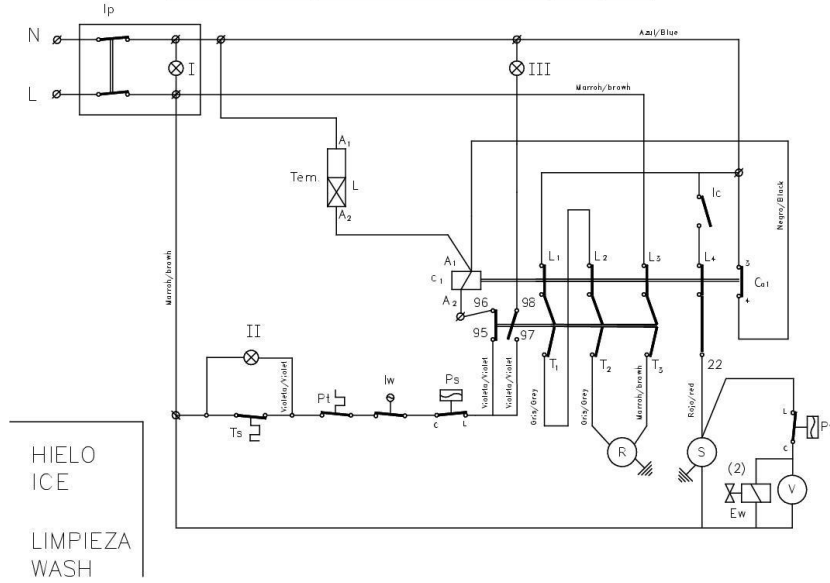

- | | |
|------------------------------------|---------------------------------|
| Tem. Star Time | Tem. Temporizador a la conexión |
| C1. Contactor | C1. Contactor |
| Pv. Fan pressostat | Pv. Presostato ventilador |
| V. Fan | V. Ventilador |
| S. Compressor | S. Compresor |
| Ip. On/Off switch | Ip. Interruptor marcha-paro |
| Ts. Full storage bin stop | Ts. Paro por llenado |
| Iw. Water low level float switch | Iw. Micro boya falta de agua |
| Ps. Safety pressostat | Ps. Presostato de seguridad |
| R. Gearmotor | R. Motorreductor |
| Pt. Motor thermal protection | Pt. Protector térmico motor |
| Ew. Condenser water valve | Ew. Electroválvula condensación |
| Ic. Cleaning switch | Ic. Interruptor de lavado |
| I. Green on | I. Verde linea |
| II. Yellow full | II. Ámbar llenado |
| III. Thermic gearmotor | III. Térmico motorreductor |
| (2). For water condenser | (2) Para condensador de agua |
| Vem. Minuterie condenser | |
| C1. Contactor | |
| Pv. Pressostat ventilation | |
| V. Moteur ventilateur | |
| S. Compresseur | |
| Ip. Interrupteur marche/arrêt | |
| Ts. Arrêt réservoir plein | |
| Iw. Flotteur de niveau d'eau | |
| Ps. Pressostat de sécurité | |
| R. Motoréducteur | |
| Pt. Protection thermique du moteur | |
| Ew. Valvule de condensation | |
| Ic. Interrupteur nettoyage | |
| I. Vert - marche | |
| II. Jaune - réservoir plein | |
| III. Térmico motorreductor | |
| (2) Pour condensateur d'eau | |

THREE-PHASE MODULAR WIRING DIAGRAM



IQ-600 R290/ trifásica esquema eléctrico - wiring diagram

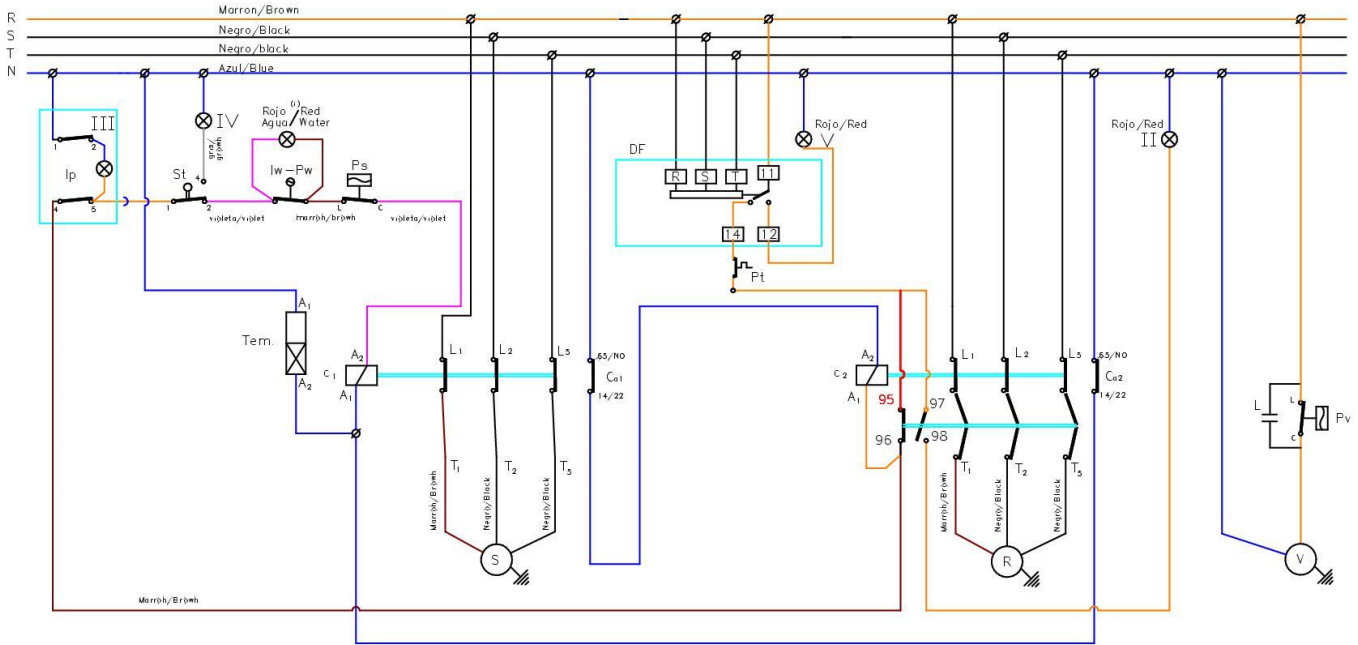

- Tem - Temporizador a la conexión/Start Timer
- C₁ - Contactor (Compresor)/Contact (Compressor)
- C₂ - Contactor (Motorreductor)/Contact (gearmotor)
- Pv - Presostato ventilador (solo cond por aire)/Fan Pressostat (only air cooled models)
- V - Ventilador/Fan
- S - Compresor/Compressor
- Ip - Interruptor de paro-marcha/On-off switch
- St - Paro por llenado/Full storage bin stop
- Iw - Micro boya falta de agua/Water low level float switch
- Pw - Presostato de agua/Water pressostat
- Ps - Presostato de seguridad/High pressure safety pressostat
- R - Motorreductor/Gearmotor
- L - Condensador filtro/Electrical interference filter (capacitador)

- Pt - Protector térmico motor/Motor thermal protection
- DF - Detector de fase/Phase sequence relay
- C₀ - Contacto auxiliar autoalimentación/Auxiliar contact feedback
- C₀₂ - Contacto auxiliar autoalimentación/Auxiliar contact feedback
- II - Térmico Motorreductor/Thermic gearmotor
- III - Azul línea / Blue on
- IV - Ambar llenado/ Yellow full
- V - Fase cambia/Phase sequence

REGULACION TERMICOS OVERLOAD SETTING	
COMPRESOR	3.6 A
MOTORREDUCTOR	1.3 A

27/04/2022

5. SEQUENCE OF OPERATION

1. Switch the machine on at the power switch.
2. When pressed, the machine is timed for 10 minutes of start-up.
3. During the start-up time, the entire hydraulic circuit is filled with water up to the buoy.
4. The water in contact with the walls of the evaporator freezes, and the ice that forms is scraped off by the SPINDLE (endless) which also pushes it upwards, forcing it to come out of the mouth and fall into the tank.
5. When it (the reservoir) is full, the ice touches the stop rocker and the machine stops. In the 45 and 85 models, the filling stop will be carried out by a thermostat. It will switch on again when the thermostat detects that the ice level has dropped.

It will start producing ice again when the ice level drops and does not touch the stop rocker.

7- ALARMS

They detect malfunctions. They are indicated by flashing lights on the control panel.

In some alarms, an automatic reset is carried out and if this does not work, the machine will stop.

To perform a manual reset, the main switch must be turned off and on.

7.1 MAGNETO-THERMAL PROTECTOR OR CIRCUIT BREAKER

Protects the motor from current peaks to prevent overheating of the motor windings.

Signalling:

- Red light specified as "thermal" on the pilot panel.
It is located in the electrical panel, so to access it it will be necessary to remove the ventilation grille and the cover that covers it.

Solution: Manual reset

7.2 THERMAL PROTECTOR OF THE GEARED MOTOR

A probe in the motor stator will cut off the current of the electrical control of the machine if the temperature in the motor increases above acceptable levels.

Signalling:

- Red light specified as "thermal" on the pilot panel.
It is located in the electrical panel, so to access it, it will be necessary to remove the ventilation grille and the cover that covers it.

Solution: automatic reset

7.3 WATER LEVEL

A magnetically operated micro switch located inside the water basin switches the machine off if the water level drops below the limit to which it is set.

Signalling:

- Red light specified as "lack of water" on the pilot panel.
It is located in the electrical panel, so to access it it will be necessary to remove the ventilation grille and the cover that covers it.

Solution: automatic reset

7.4 STOP DUE TO ICE FILLING

Located in front of the gear motor, it rests its arm on a tilting plate, in such a way that, if the ice rises up the ice drop pipe and pushes the said plate, the micro switch will stop the machine.

Signalling:

- Orange light on the pilot panel.
It is located in the electrical panel, so to access it it will be necessary to remove the ventilation grille and the cover that covers it.

Solution: Automatic reset

8. MAINTENANCE AND CLEANING PROCEDURES

It is the responsibility of the user to maintain the ice machine and ice storage bin in a hygienic condition.

Ice machines also require occasional cleaning of their water systems with a specifically designed chemical. This chemical dissolves mineral buildup that forms during the ice making process.

Disinfect the ice storage bin as often as required by local sanitary codes, and each time the ice machine is cleaned and disinfected.

The ice machine water system should be cleaned and sanitized at least twice a year.

CAUTION: Do not mix ice machine cleaner and sanitizer solutions.

WARNING: Wear rubber gloves and safety glasses when handling ice machine cleaner or disinfectant.

WARNING: The unit should always be disconnected during maintenance/cleaning procedures.

RUBBER GLOVES AND SAFETY GOGGLES SHOULD BE WORN WHEN HANDLING ICE MACHINE CLEANER OR SANITIZER.

8.1 CLEANING OF AIR CONDENSER

1. Disconnect the power supply of the machine.
2. Close the water inlet valve or the faucet.
3. Clean with the aid of a vacuum cleaner, non-metallic brush or low-pressure air.
4. Open the water inlet valve or faucet.
5. Turn on the power supply to the machine.

8.2 CLEANING OF WATER CONDENSER

1. Disconnect the power supply of the machine.
2. Close the water inlet valve or faucet.
3. Disconnect the water inlet and outlet of the condenser.
4. Prepare the cleaning product Calkin or in its absence a 50% solution of phosphoric acid and distilled or demineralized water.
5. Circulate it through the condenser. The mixture is most effective between 35°C and 40°C.
6. Remove the product from the condenser and reconnect the water inlet and outlet.
7. Open the water inlet valve or tap.
8. Turn on the power supply to the machine.

8.3 CHANGE OF WATER FILTER

1. Disconnect the power supply of the machine.
2. Close the water inlet valve or the faucet.
3. Close the stopcocks located before and after the filter.
4. Remove the cartridge and install the new one.
5. Open the water inlet valve or faucet.
6. Turn on the power supply to the machine.

8.4 CLEANING THE HYDRAULIC CIRCUIT:

1. Disconnect the power supply to the machine.
2. Close the water tap.

Modular machines: Disconnect the compressor directly from the contactor installed on the electrical panel.

Compact machines: 50 and 85, set the cleaning switch on the control panel to 0 to stop the compressor

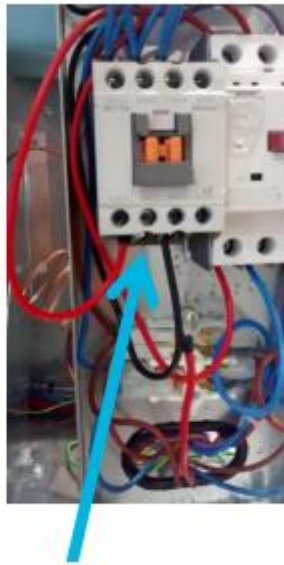
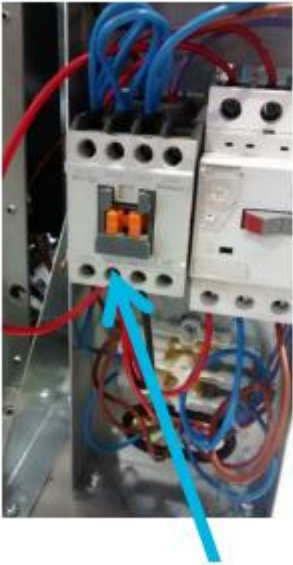

Modular machines: red contactor to compressor output cable (intermediate)

Non-modular units: disconnect red output cable to compressor contactor.

1. Disconnect the water inlet pipe to the evaporator.
2. Remove the overflow pipe from the water tank.



Tubo evaporador



Tubo rebosadero



1. Let the water flow for two to three minutes.
2. Once the evaporator is completely empty, reconnect the hoses to the evaporator and to the water tank.
3. Prepare a 50% solution of phosphoric acid and water, or use an anti-scale cleaner such as ITV's Calklin. Do not use sulfamic acid or hydrochloric acid. Pour this solution slowly into the water tank (remove the lid). The mixture is most effective when hot, between 35°C and 40°C.
4. Turn on the power supply and switch on the machine.
5. Leave the solution to act for 20 minutes.
6. After 20 minutes, stop the machine and disconnect the water inlet pipe to the evaporator to completely empty the product used for cleaning.
7. Once empty, open the tap to introduce clean water into the circuit.
8. Switch on the machine, connecting the contactor installed on the electrical panel.
9. For compact machines: 50 and 85, set the cleaning switch installed on the control panel to 1 and allow the machine to produce ice.

WARNING: Discard the ice produced within 5 minutes.

Cleaning the stock tank.

Switch off the machine, turn off the water and empty the stock of ice cubes.

Use a kitchen cloth with detergent.

If the white limescale stains are not removed, rub them with lemon juice, wait for a while and wipe again.

Rinse with plenty of water, dry and restart the machine.

Exterior cleaning

Use the same procedure as for the stock tank.

8.7 MAINTENANCE TABLE

ACTION	MONTHLY	QUARTERLY	SEMESTERLY	ANNUAL	BIENNIAL	T UNIT
Cleaning air condenser						30 minutes
Cleaning water condenser						90 minutes
Descaling						45 minutes
Disinfection						30 minutes
Cleaning/exchange water filters						30 minutes
Exterior cleaning						--

	Depending on the characteristics of the environment
	Indispensable/Essential
	Depending on water quality
	Performed by owner

Maintenance and cleaning procedures, as well as problems resulting from their non-performance, **ARE NOT COVERED BY THE GUARANTEE.** Service personnel will bill you for travel expenses, time spent and materials required for maintenance and cleaning of the unit.

9. TROUBLESHOOTING GUIDE

PROBLEMS	POSSIBLE CAUSES	SOLUTION
None of the electrical systems work. Front display off	No power.	Check power supply and connection
	Switch OFF	Power on
	Display connector loosened	Check. Insert
Safety pressure switch	Dirty condenser	Clean the condenser
	Poorly positioned machine	Change location.
	Defective ventilator	Check. Replace
	Water machine: water valve broken	Check. Replace
	Defective safety pressure switch	Check. Replace
Lack of water consumption	Poor cooling system performance	Check/replace
	Stop mike doesn't switch on	Adjust or replace the microphone
	Timer faulty	Replace
	Evaporator water inlet clogging	Check/clean
Low water level	Lack of water supply	Check power supply Check filter gasket
	Evaporator inlet tube loose	Adjust pipe
	Stop mike doesn't switch on	Adjust or replace the microphone
	Timer faulty	Replace
Gear motor shutdown due to temperature	Condenser deterioration	Check. Replace
	Incorrect switch configuration	Check and change
	Internal probe failure	Check. Replace
Gear motor shutdown due to low current	No voltage to motor	Check wiring and plate output
	Motor with open winding	Replace geared motor
Gear motor stop due to high current	Over-stressing/blocking of the gear unit	Check evaporator (condition and cleanliness)
	Deterioration of condenser	Check. Replace
	Defective geared motor	Check. Replace
Compressor does not run, but voltage is supplied	Compressor/electrical equipment defective	Check/replace
Compressor runs, but does not cool Plate is energized, but does not turn on	Refrigeration system not working properly	Check load and components
Shutdown due to full store, but no ice	Internal board fuse open	Replace (0.5 A)
	Modular: stop rocker stays up.	Check that it moves freely.
	Condition of full container without ice. Thermostat defective or incorrectly set Modular: faulty micro	Adjust or replace Substitute
Low ice production	Condenser blocked or air access to the condenser	Check/replace
	Hot gas valve defective, does not close completely	Clean condenser, improve air circulation
	Refrigeration system underperforming	Substitute

PROBLEMS	POSSIBLE CAUSES	SOLUTION
Ice storage is flooded	Check if valve is blocked	Clean or replace it
	Pump is broken	Replace pump
Everything works, but it doesn't make ice	Refrigerant leakage.	Locate leak, repair and refrigerant recharge
	Defective compressor.	Replace compressor
	Expansion valve closed or clogged or capillary clogged.	Open valve passage or replace valve (change capillary and filter drier)
	Water/moisture in refrigeration system.	Change compressor oil, change capillary and dehydrator (fit an antacid one), carry out vacuum of the system, slightly heating all components and charge refrigerant.
The machine works intermittently	Water mains pressure less than 0.7 bar	This problem is exacerbated by the size of the machines. In the case of small machines, it is sometimes possible to solve this problem by regulating the float in the water tank. IF IT IS NOT POSSIBLE TO INSTALL A BOOSTER SET IN THIS WAY
	Normal water mains pressure (0.7 to 6.5 bar)	Regulating the water level in the water tank.
Very wet ice	Very high ambient temperature (> 35° C)	Change the location of the machine, if possible.
	Very high water temperature (> 30° C)	Check the piping and filter in case condensation air or other heat source heats up the water in the pipes.
	Low water quality (> 1500)	Lower the position of the water tank. Install water treatment equipment.
	Dirty condenser	Clean
	Pressure-tight valve too closed or too closed or defective.	Adjust or replace
	Lack of compressor cooling	Substitute
	Refrigerant leakage	Refill and in case of leakage, repair.
	Low water level in the tank, the water consumption is higher water consumption is higher than the water entering through the float valve.	Check the pressures in the water system. Check that the filters or float valve are not clogged. Adjust the water level.

10. OTHER TECHNICAL INFORMATION

For more technical information, scan the QR code below or click on the link:



- Technical Data Sheets
- User's manual
- Parts
- CAD / REVIT
- Technical videos

<https://acortar.link/yqDOHZ>