

MDP INSTRUCTIONS STACKING KIT

ELECTRICAL SCHEME STACKING KIT

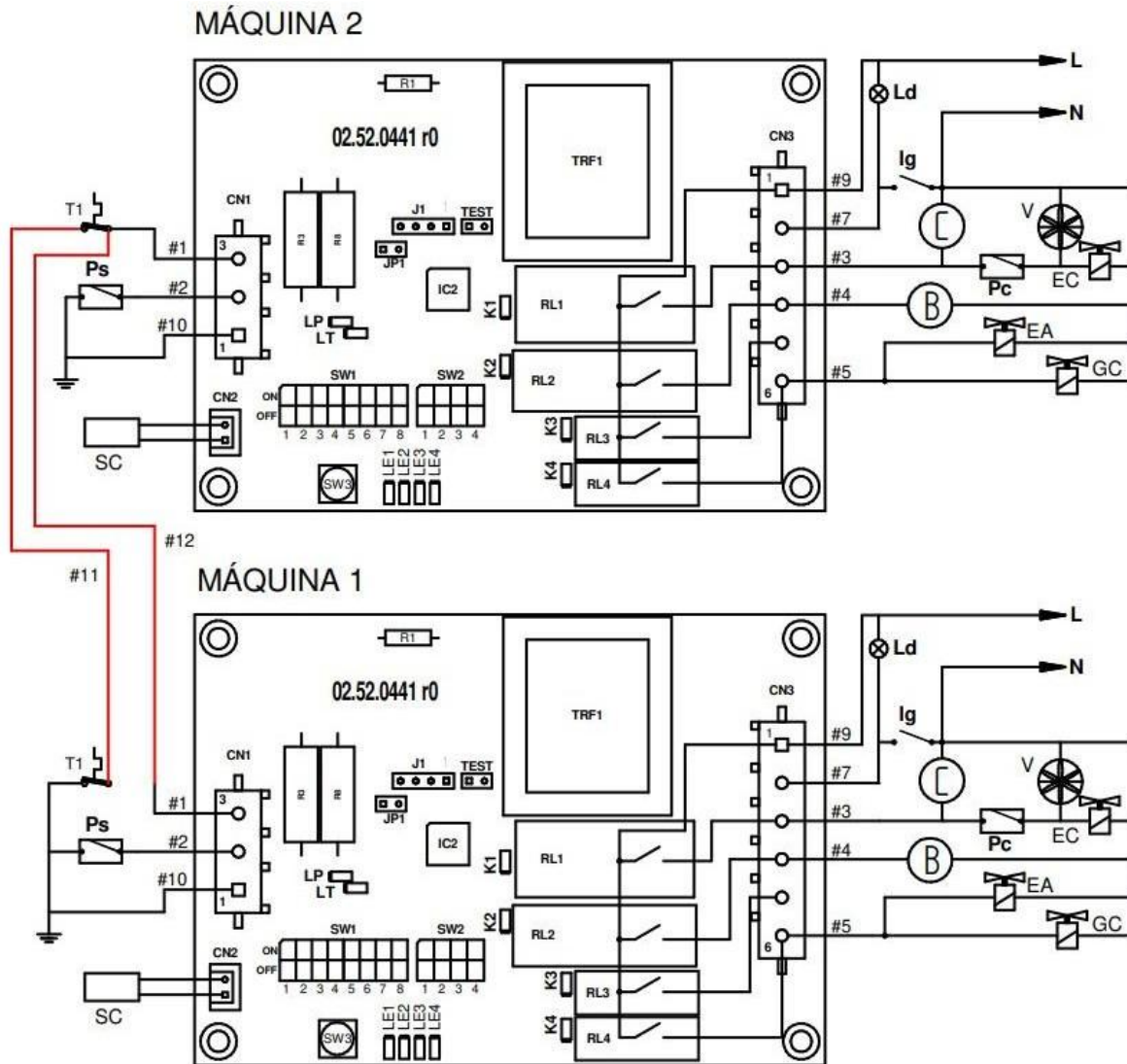

- SC.-Sonda de Ciclo / Harvest Assist Probe
 T1.-Termostato de stock / Bin Sens or
 EA.-Electroválvula entrada agua / Water Inlet electrovalve
 GC.-Electroválvula de gas caliente / Hot gas/Harvest electrovalve
 C.-Compresor / Compressor
 B.-Bomba de agua / Water Pump
 Ps.-Presostato Seguridad / High Pressure cut out
 V.-Ventilador (solo condensación aire) / Fan (only air condensation)
 EC.-Electroválvula de condensación/ Condensation electrovalve
 (solo condensación agua) (only water condensation.)
 Ig.-Interruptor general / Power Switch
 Pc.-Presostato Condensación Ventilador / Fan Control Switch

- | | |
|----------------------------|-----------------------|
| #1 black/ negro | #7 blue/ azul |
| #2 white / blanco | #8 grey/ gris |
| #3 red / rojo | #9 brown/ marrón |
| #4 orange / naranja | #10 yellow / amarillo |
| #5 violet / violeta | #11 grey / gris |
| #6 ground / verde-amarillo | #12 grey / gris |

MODULAR MODELS - FILL STOP KIT.

When two modular machines are operated stacked (one on top of the other), the stop of the set will be determined by the stock thermostat of the machine installed at the bottom thanks to the supplied kit.

Thus, when the stock thermostat determines that the storage is full of ice (detects a temperature between 1 and 5°C), it will cause the independent stop of the machines just at the moment when the manufacturing cycle ends and the cube release cycle begins, that is, unless they coincide, the machines will not stop at the same time.

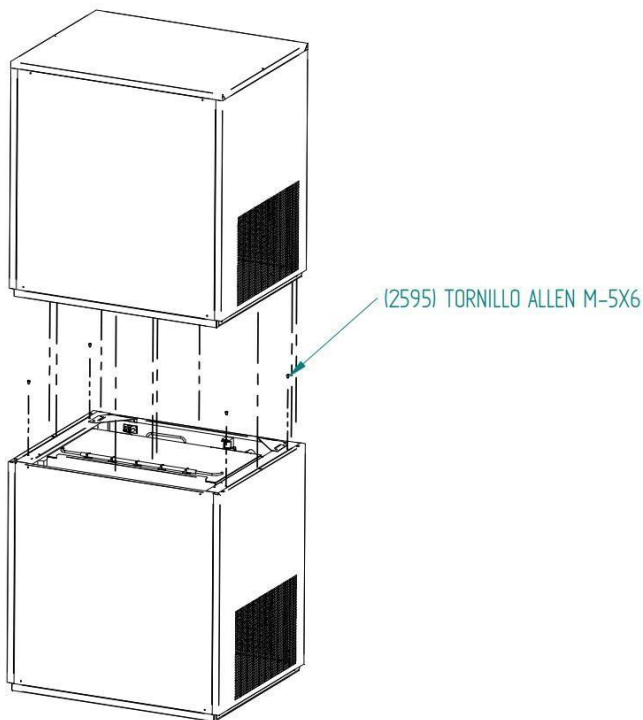

For stacking the machines, 4 screws are added to the top of the lower machine (machine 1) once its cover is removed. Next, the second machine (machine 2) is placed on top, fitting the added screws into the holes in the base provided for this purpose. This way, the upper machine is secured.

At the base, a hole can be seen to connect the cables between the machines..

Agujero para el conexionado entre máquinas

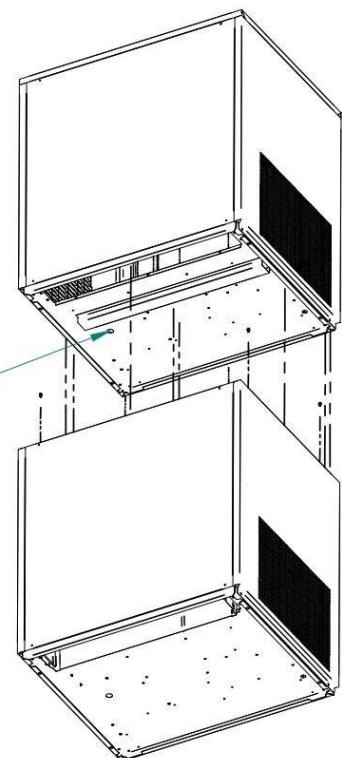

Next, the installation of the fill stop kit is detailed:

In the first images, the connection of the stock thermostat can be seen both in the panel of the lower machine (machine 1) and the panel of the upper machine (machine 2)..



Diagram Machine 1



Diagram Machine 2

Then, the black cable #1 from the thermostat must be disconnected from the panel of machine 1 and the yellow cable from the panel of machine 2. In these connections that have been left free in the thermostats, the gray cable #11 should be connected. Then, the gray cable #12 should be connected with the black cable #1 of machine 1 that we previously disconnected and with the black cable #1 of machine 2 as shown in the images..



Diagram Machine 1 Stacking Kit Wiring

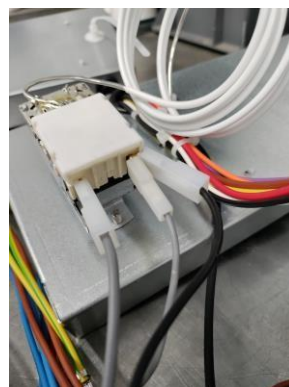

Diagram Machine 2 Stacking Kit Wiring



Connection Gray Cable #12 and Black Cable #1